

# OPERATION AND PARTS MANUAL



## **Vibratory Walk-Behind Roller *Mikasa* Model MDR-9GH (Honda Gasoline)**

© COPYRIGHT 2003, MULTIQUIP INC.

Revision #0 (12/17/03)



**MULTIQUIP INC.**

18910 WILMINGTON AVE.  
CARSON, CALIFORNIA 90746  
310-537-3700  
800-421-1244  
FAX: 310-537-3927

**E-mail:** [mq@multiquip.com](mailto:mq@multiquip.com) • **www:** [www.multiquip.com](http://www.multiquip.com)

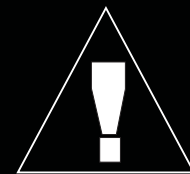
**PARTS DEPARTMENT:**

800-427-1244  
FAX: 800-672-7877  
**SERVICE DEPARTMENT/TECHNICAL ASSISTANCE:**  
800-478-1244  
FAX: 310-631-5032

Atlanta • Boise • Dallas • Houston • Newark  
Montreal, Canada • Manchester, UK  
Rio De Janeiro, Brazil • Guadalajara, Mexico



# WARNING



## **CALIFORNIA — Proposition 65 Warning**

Engine exhaust and some of its constituents are known to the State of California to cause cancer, birth defects and other reproductive harm.

## **HERE'S HOW TO GET HELP**

PLEASE HAVE THE MODEL AND SERIAL  
NUMBER *ON-HAND* WHEN CALLING

### ***MULTIQUIP'S MAIN PHONE NUMBERS***

800-421-1244      FAX: 310-537-3927  
310-537-3700

### ***PARTS DEPARTMENT***

800-427-1244      FAX: 800-672-7877  
310-537-3700      FAX: 310-637-3284

### ***MAYCO PARTS***

800-306-2926      FAX: 800-672-7877  
310-537-3700      FAX: 310-637-3284

### ***SERVICE DEPARTMENT***

800-478-1244      FAX: 310-537-4259  
310-537-3700

### ***MQ POWER SERVICE DEPARTMENT***

800-835-2551      FAX: 310-638-8046  
310-537-3700

### ***TECHNICAL ASSISTANCE***

800-478-1244      FAX: 310-631-5032

### ***WARRANTY DEPARTMENT***

800-421-1244, EXT. 279      FAX: 310-537-1173  
310-537-3700, EXT. 279

## MIKASA MDR-9GH-VIBRATORY ROLLER

Proposition 65 Warning .....	2
Here's How To Get Help .....	3
Table Of Contents .....	4
Parts Ordering Procedures .....	5
Specifications .....	6
Dimensions .....	7
Safety Message Alert Symbols .....	8-9
Rules for Safe Operation .....	10-11
Operation and Safety Decals .....	12
General Information .....	14-15
Vibratory Roller Components .....	16
Engine Components .....	17
Inspection/Start-Up .....	20-21
Operation/Lifting/Transporting .....	22-23
Maintenance .....	24-29
Engine Troubleshooting .....	30-31
Roller Troubleshooting .....	32
Explanation Of Code In Remarks Column .....	34
Suggested Spare Parts .....	35

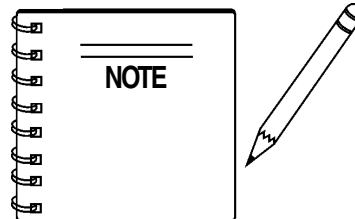
## PARTS ILLUSTRATIONS

Decal Placement .....	36-37
Body Assembly .....	38-39
Front Cover Assembly .....	40-43
Axle Assembly .....	44-47
Transmission Assembly .....	48-49
Hydraulic Oil Tank Assembly .....	50-51
Clutch Box Assembly .....	52-55
Vibration Case Assembly .....	56-57
Upper Control Handle Assembly .....	58-61
Lower Control Handle Assembly .....	62-63
Engine Assembly .....	64-65
Battery Assembly .....	66-67

## HONDA GX340K1QAE2 ENGINE

Air Cleaner Assembly .....	68-69
Camshaft Assembly .....	70-71
Carburetor Assembly .....	72-73
Control Assembly .....	74-75
Control Box Assembly .....	76-77
Crankcase Cover Assembly .....	78-79
Crankshaft Assembly .....	80-81
Cylinder Barrel Assembly .....	82-83
Cylinder Head Assembly .....	84-85
Fan Cover Assembly .....	86-87
Flywheel Assembly .....	88-89
Fuel Tank Assembly .....	90-91
Ignition Coil Assembly .....	92-93
Starter Motor Assembly .....	94-95
Muffler Assembly .....	96-97
Piston Assembly .....	98-99
Recoil Starter Assembly .....	100-101
Labels Assembly .....	102-103

Terms and Conditions of Sale .....	104
------------------------------------	-----



Specification and part number are subject to change without notice.

# PARTS ORDERING PROCEDURES

## When ordering parts, please supply the following information:

- Dealer account number
- Dealer name and address
- Shipping address (if different than billing address)
- Return fax number
- Applicable model number
- Quantity, part number and description of each part
- Specify preferred method of shipment:
  - ✓ FedEx or UPS Ground
  - ✓ FedEx or UPS Second Day or Third Day
  - ✓ FedEx or UPS Next Day
  - ✓ Federal Express Priority One
  - ✓ DHL
  - ✓ Truck

*Note: Unless otherwise indicated by customer, all orders are treated as "Standard Orders", and will ship within 24 hours. We will make every effort to ship "Air Shipments" the same day that the order is received, if prior to 2PM west coast time. "Stock Orders" must be so noted on fax or web forms.*



## Here's how to get help...

Please have the model and serial number on hand when calling.

### Parts Department

800-427-1244  
310-537-3700

Fax: 800-672-7877  
Fax: 310-637-3284

### Mayco Parts

800-306-2926  
310-537-3700

Fax: 800-672-7877  
Fax: 310-637-3284

### Service Department

800-478-1244  
310-537-3700

Fax: 310-537-4259

### MQ Power Service Department

800-835-2551  
310-537-3700

Fax: 310-638-8046

### Technical Assistance

800-478-1244

Fax: 310-631-5032

### Warranty Department

800-421-1244, Ext. 279  
310-537-3700, Ext. 279

Fax: 310-537-1173

### Multiquip's Main Phone Numbers

800-421-1244  
310-537-3700

Fax: 310-537-3927



**MULTIQUIP INC.**  
18910 WILMINGTON AVENUE  
POST OFFICE BOX 6254  
CARSON, CALIFORNIA 90749  
310-537-3700 • 800-421-1244  
FAX: 310-537-3927  
E-MAIL: mq@multiquip.com  
WWW: multiquip.com

## Place Your Parts Order Via Web or Fax For Even More Savings!

### Extra Discounts!

All parts orders which include complete part numbers and are received by our automated web parts order system, or by fax qualify for the following extra discounts:

Ordered via	Standard orders	Stock orders (\$750 list and above)
Fax	3%	10%
Web	5%	10%

### Special freight allowances when you order 10 or more line items via Web or Fax! \*\*

FedEx Ground Service **at no charge for freight**

No other allowances on freight shipped by any other carrier.

NOTE: DISCOUNTS ARE SUBJECT TO CHANGE

## Direct TOLL-FREE access to our Parts Department:

Toll-free nationwide — 800-427-1244

# MDR-9GH — SPECIFICATIONS

**Table 1. MDR-9GH VIBRATORY ROLLER SPECIFICATIONS**

Centrifugal Force	6,600 lbs. (3,000 kg)
Vibration Frequency	3,000 vpm
Traveling Speed (forward and reverse)	0 to 1.8 mph (0 to 3 km/hr)
Grade Ability	25°
Diameter x Width of Roller	18 x 27.6 in (457 x 700 cm)
Wheel Base	22.4 in (570 mm)
Side Road Clearance	10.8 in (274 mm)
Length (with Handle)	111.8 in (2,840 mm)
Width	31.3 in (795 mm )
Height	44.1 in (1,120 mm )
Total Weight	1,940 lbs. (880 kg)
Working Input Revolution	2,000 rpm
Continuous Rated Pressure	1,500 psi (105 kg/cm <sup>2</sup> )
Oil Tank Capacity	4 gallons (15 liters)
Water Tank Capacity	6 gallons (23 liters)
Working Ability	2,100 m <sup>2</sup> /hr

**Table 2. ENGINE SPECIFICATIONS**

<b>Engine</b>	<b>Model</b>	<b>HONDA GX340K1QAE2</b>
	Type	Air-cooled 4 stroke, Single Cylinder, OHV, Horizontal Shaft Gasoline Engine
	Bore X Stroke	2.90 in. X 2.30 in. (73 mm x 58 mm.)
	Displacement	23.70 cu-in (389 cm <sup>3</sup> )
	Max Output	11.0 H.P./3600 R.P.M.
	Fuel Tank Capacity	1.72 gallons (6.5 liters)
	Fuel	Unleaded Automobile Gasoline
	Lube Oil Capacity	1.16 quarts (1.1 liters)
	Oil Alert System	Yes
	Speed Control Method	Centrifugal Fly-weight Type
	Starting Method	Electric/Recoil Start
<b>Dimension (L x W x H)</b>	15.0 x 17.7 X 17.4 in. (380 X 450 X 443 mm.)	
<b>Dry Net Weight</b>	68.4 lbs (31 Kg.)	

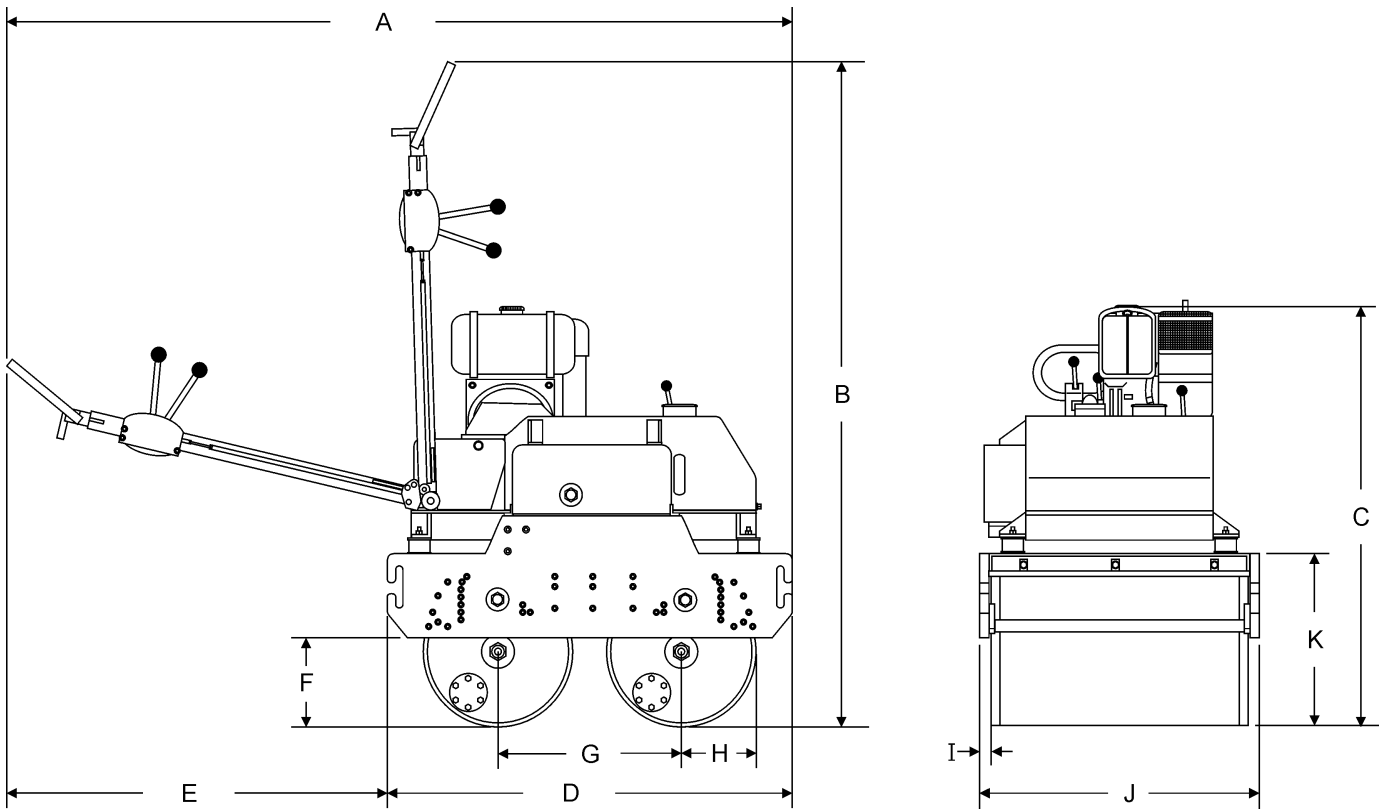


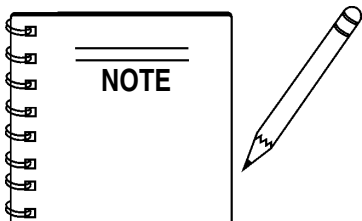
Figure 2. MDR-9GH Vibratory Roller Dimensions

TABLE 3. ROLLER DIMENSIONS			
REF.	DIMENSIONS	REF.	DIMENSIONS
A	111.8 in. (2.8 meters)	F	22.4 in. (.57 meters)
B	88 in. (2.23 meters)	G	18 in. (.457 meters)
C	46 in. (1.17 meters)	H	15.5 in. (.382 meters)
D	45.9 in. (1.16 meters)	I	5.4 in. (.137 meters)
E	11 in. (.279 meters)		

# MDR-9GH — SAFETY MESSAGE ALERT SYMBOLS

## FOR YOUR SAFETY AND THE SAFETY OF OTHERS!

Safety precautions should be followed at all times when operating this equipment. Failure to read and understand the Safety Messages and Operating Instructions could result in injury to yourself and others.



This Owner's Manual has been developed to provide complete instructions for the safe and efficient operation of the Multiquip Model MDR-9GH Vibration Roller. Refer to the engine manufacturer's instructions for data relative to its safe operation.

**Before using this vibratory roller, ensure that the operating individual has read and understands all instructions in this manual.**

## SAFETY MESSAGE ALERT SYMBOLS

The three (3) Safety Messages shown below will inform you about potential hazards that could injure you or others. The Safety Messages specifically address the level of exposure to the operator, and are preceded by one of three words: **DANGER**, **WARNING**, or **CAUTION**.



**DANGER:** You **WILL** be **KILLED** or **SERIOUSLY** injured if you do not follow directions.



**WARNING:** You **CAN** be **KILLED** or **SERIOUSLY** injured if you do not follow directions.



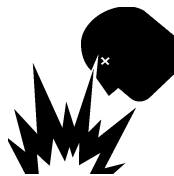
**CAUTION:** You **CAN** be injured if you do not follow directions.

Potential hazards associated with this vibratory roller operation will be referenced with Hazard Symbols which appear throughout this manual, and will be referenced in conjunction with Safety Message Alert Symbols.

## HAZARD SYMBOLS



### Lethal Exhaust Gases



Engine exhaust gases contain poisonous carbon monoxide. This gas is colorless and odorless, and can cause death if inhaled. **NEVER** operate this equipment in a confined area or enclosed structure that does not provide ample free flow air.



### Explosive Fuel



**GASOLINE** is extremely flammable, and its vapors can cause an explosion if ignited. **DO NOT** start the engine near spilled fuel or combustible fluids. **DO NOT** fill the fuel tank while the engine is running or hot. **DO NOT** overfill tank, since spilled fuel could ignite if it comes into contact with hot engine parts or sparks from the ignition system. Store fuel in approved containers, in well-ventilated areas and away from sparks and flames. **NEVER** use fuel as a cleaning agent.



### Burn Hazards



Engine components can generate extreme heat. To prevent burns, **DO NOT** touch these areas while the engine is running or immediately after operations. Never operate the engine with heat shields or heat guards removed.



### Rotating Parts



**NEVER** operate equipment with covers, or guards removed. Keep fingers, hands, hair and clothing away from all moving parts to prevent injury.



# MDR-9GH — SAFETY MESSAGE ALERT SYMBOLS

## Accidental Starting



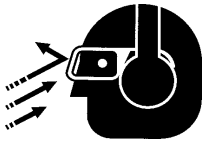
**OFF** **ALWAYS** place the engine ON/OFF switch in the **OFF** position, when the vibration roller is not in use.

## Respiratory Hazard



**ALWAYS** wear approved respiratory protection.

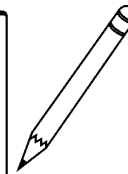
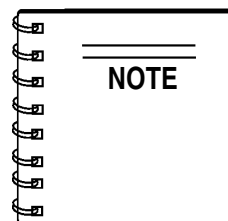
## Sight and Hearing hazard



**ALWAYS** wear approved eye and hearing protection.

## Equipment Damage Messages

Other important messages are provided throughout this manual to help prevent damage to your vibration roller, other property, or the surrounding environment.



This vibratory roller, other property, or the surrounding environment could be damaged if you do not follow instructions.

# MDR-9GH — RULES FOR SAFE OPERATION

## CAUTION:



Failure to follow instructions in this manual may lead to serious injury or even death! This equipment is to be operated by trained and qualified personnel only! This equipment is for industrial use only.

The following safety guidelines should always be used when operating the MIKASA MDR-9GH Vibratory Roller.

### GENERAL SAFETY

- **DO NOT** operate or service this equipment before reading this entire manual.



- This equipment should not be operated by persons under 18 years of age.

- **NEVER** operate this equipment without proper protective clothing, shatterproof glasses, steel-toed boots and other protective devices required by the job. **ALWAYS** wear slip resistant safety shoes or boots.



- **NEVER** operate this equipment when not feeling well due to fatigue, illness or taking medicine.



- **NEVER** operate this equipment under the influence of drugs or alcohol.

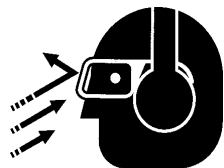


- **NEVER** use accessories or attachments, which are not recommended by Multiquip for this equipment. Damage to the equipment and/or injury to user may result.

- Manufacturer does not assume responsibility for any accident due to equipment modifications.

- Whenever necessary, replace nameplate, operation and safety decals when they become difficult read.

- **ALWAYS** wear proper respiratory (mask), hearing and eye protection equipment when operating the vibratory roller.

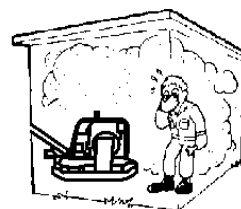


- **NEVER** touch the hot exhaust manifold, muffler or cylinder. Allow these parts to cool before servicing engine or vibratory roller.



- **High Temperatures** – Allow the engine to cool before adding fuel or performing service and maintenance functions. Contact with *hot* components can cause serious burns.

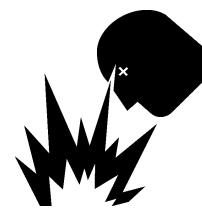
- The engine of this vibratory roller requires an adequate free flow of cooling air. **NEVER** operate the vibratory roller in any enclosed or narrow area where free flow of the air is restricted. If the air flow is restricted it will cause serious damage to the vibratory roller or engine and may cause injury to people and property. Remember the roller's engine gives off **DEADLY** gases.



- **ALWAYS** refuel in a well-ventilated area, away from sparks and open flames.

- **ALWAYS** use extreme caution when working with **flammable** liquids. When refueling, **stop the engine** and allow it to cool. **DO NOT** smoke around or near the machine. Fire or explosion could result from fuel vapors, or if fuel is spilled on a hot engine.

- **NEVER** operate the vibratory roller in an explosive atmosphere or near combustible materials. An explosion or fire could result causing severe *bodily harm or even death*.



- Topping-off to filler port is dangerous, as it tends to spill fuel.

- **ALWAYS** store the vibratory roller in a clean, dry location out of the reach of children.

- **NEVER** run engine without air cleaner. Severe engine damage may occur.

- **NEVER** leave the vibratory roller unattended, turn off engine.

- **CAUTION** must always be observed while servicing this vibratory roller. Rotating parts can cause injury if contacted.

- **DO NOT** leave vibratory roller with engine running. Use chock blocks if parking vibratory roller on a grade.

# MDR-9GH — RULES FOR SAFE OPERATION

- **NEVER** disconnect any "**emergency or safety devices**". These devices are intended for operator safety. Disconnection of these devices can cause severe injury, bodily harm or even death! Disconnection of any of these devices will void all warranties.

## Loading and Unloading (Crane)

- Before lifting, make sure that machine parts (hook and vibration insulator) are not damaged and screws are not loosened or lost.
- Always make sure crane or lifting device has been properly secured to the hook of guard frame on vibratory roller.
- **NEVER** lift the machine while the engine is running.
- Use adequate lifting cable (wire or rope) of sufficient strength.
- Use one point suspension hook and lift straight upwards.
- **NEVER** allow any person or animal to stand underneath the machine while lifting.
- Try not to lift machine to unnecessary heights.

## Transporting

- Always shutdown engine before transporting.
- Tighten fuel tank cap securely and close fuel cock to prevent fuel from spilling.
- Drain fuel when transporting vibratory roller over long distances or bad roads.
- Always tie-down the vibratory roller during transportation by securing the roller's guard frame with rope.

## Emergencies

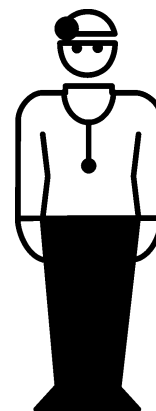
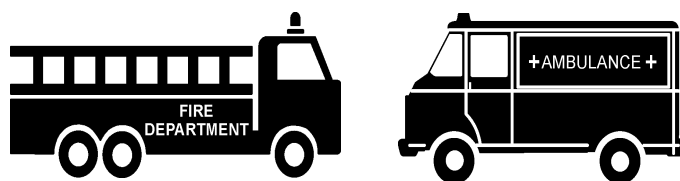
- **ALWAYS** know the location of the nearest **fire extinguisher**.



- **ALWAYS** know the location of the nearest and **first aid kit**.



- In emergencies **always** know the location of the nearest phone or **keep a phone on the job site**. Also know the phone numbers of the nearest **ambulance, doctor** and **fire department**. This information will be invaluable in the case of an emergency.

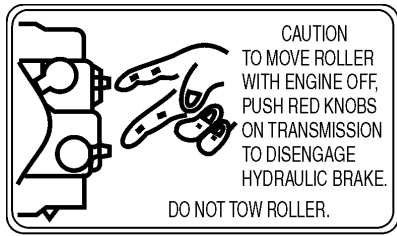


## Maintenance Safety

- **NEVER** lubricate components or attempt service on a running machine.
- **ALWAYS** allow the machine a proper amount of time to cool before servicing.
- Keep the machinery in proper running condition.
- Fix damage to the machine immediately and always replace broken parts.
- Dispose of hazardous waste properly. Examples of potentially hazardous waste are used motor oil, fuel and fuel filters.
- **DO NOT** use food or plastic containers to dispose of hazardous waste.
- **DO NOT** pour waste, oil or fuel directly onto the ground, down a drain or into any water source.

# MDR-9GH — OPERATION AND SAFETY DECALS

Figure 1 displays the operation and safety decals as they appear on the vibratory roller. Should any of these decals become damaged or unreadable, contact the Multiquip Parts Department for a replacement set.



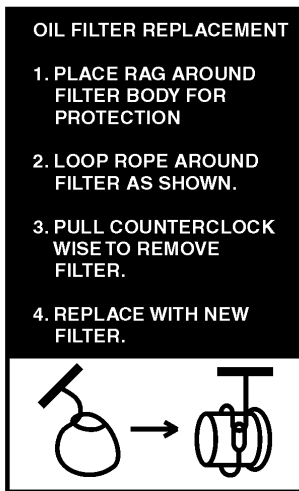
P/N: 920200440

*Mikasa*

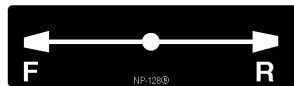
P/N: 920101510



P/N: 920201590



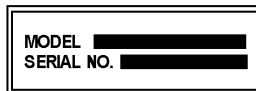
P/N:920200450



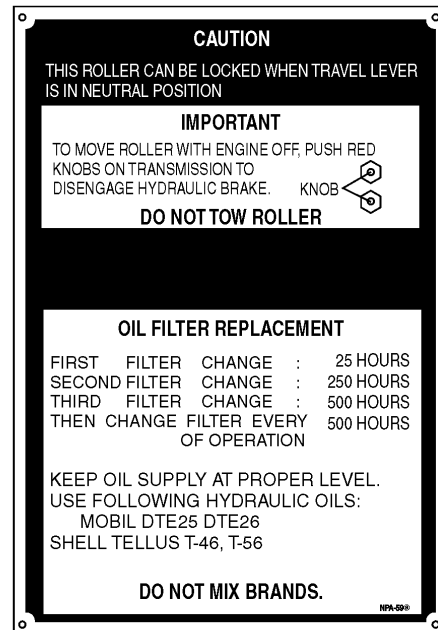
P/N:920101280



P/N: 920101480



CONTACT SERVICE DEPT.



P/N: 902000591



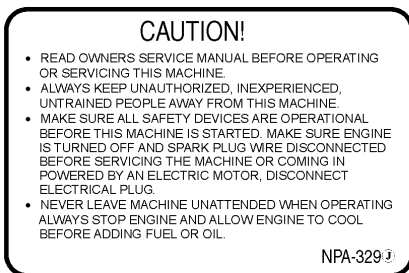
P/N:920101290



P/N:920100120



P/N: 920200320



P/N:920203290



P/N: 920200470



P/N:920201100

Figure 1. Operation and Safety Decals



# MDR-9GH — GENERAL INFORMATION

The Mikasa Model MDR-9GH is a powerful compacting tool capable of applying a tremendous force in consecutive impacts to a soil surface. With 28-inch drums and 32 inches overall width, virtually any asphalt or mixed granular soil compaction job is quickly cut down to size.

The impact force of the MDR-9GH levels and uniformly compacts voids between soil particles to increase dry density.

Features include:

- Hydraulic variable speed transmission assures easy handling.
- Deadman device which when pressed or hit will cause the travel lever to return to neutral position bringing the machine to a stop.
- Non-corrosive water tank for the sprinkler system with a capacity of 6 gallons.
- Simple dual-lever controls assure operator safety and convenience.
- Sight gauge for hydraulic oil tank.
- Front -mounted auxiliary travel lever.
- Four large rubber shock mounts minimize vibrations to the engine and hydraulics.
- Convenient tie-downs, front and rear.
- Scraper Bar.
- Drum sprinkler system.
- Handle folds to 90 degrees for storage and transport..

## FREQUENCY/SPEED

The vibrating roller maximum frequency is 3000 vpm (vibrations per minute). The forward and reverse travel speed of the vibratory roller is approximately 1.8 mph (3 km/hour).

## ENGINE

The Mikasa MDR-9GH Vibratory Roller is equipped with a HONDA GX340KQAE2 engine.

## CONTROLS

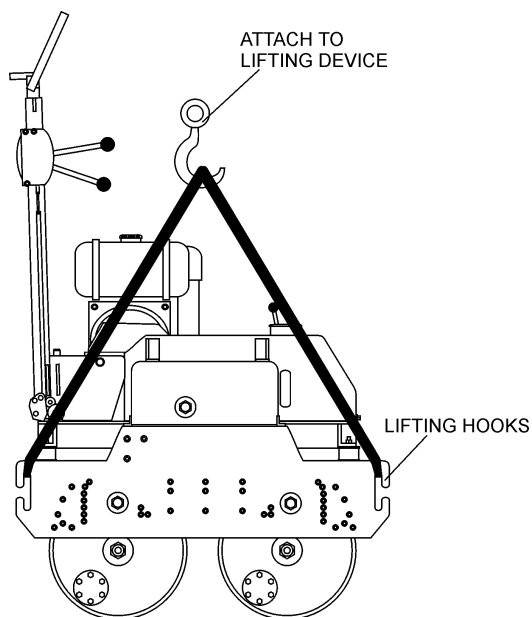
Before starting the MDR-9GH Vibratory Roller, identify and understand the function of the controls and components as indicated in Figure 6.

## TRANSPORTATION

Adjustable transport hooks allow an operator to place the roller on the tailgate of a dump truck without any assistance. The control handle of the MDR-9GH Vibratory Roller can be folded vertically for ease of transport and storage.

## LIFTING THE ROLLER

When lifting of the roller is required (Figure 3), attach a suitable hook or shackle to the **lifting hooks** of the roller. Make sure the lifting device is capable of lifting 1,940 lbs (880 kg).



NOTE: USE LIFTING HOOKS ON BOTH SIDES WHEN LIFTING

Figure 3. Lifting The Roller

# MDR-9GH — GENERAL INFORMATION

## CAUTION :



**NEVER!** stand under, or get onto the roller while it is being lifted or moved.

## CAUTION :



**ONLY!** use steel ropes or chains that are capable of lifting at least 1,940 lbs. (880 kg).

## CAUTION :



**NEVER!** use any other part of the roller for lifting purposes. Use the lifting eye. Using other parts of the roller for lifting will cause severe damage to the roller,

## OPERATING ON SLOPES

Special care must be taken when operating the roller on hills or slopes. There exist the possibility of serious injury to the operator and severe damage to the roller in the event of a roll over. **ALWAYS** operate the roller up and down hills rather than from side to side. For safe operation hillside slopes should not exceed 12 degree (21 % grade). See Figure 4 below.

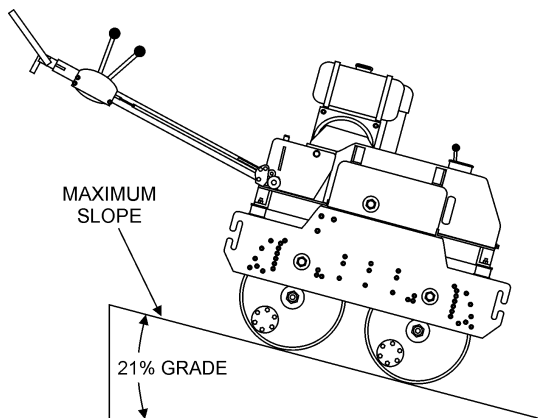


Figure 4. Recommended Slope

## Tipping (Rollovers)

**NEVER!** operate the roller on side slopes (Figure 5). The possibility exist that the roller could tip over (roll over), thus causing bodily harm even death and serious damage to the equipment.

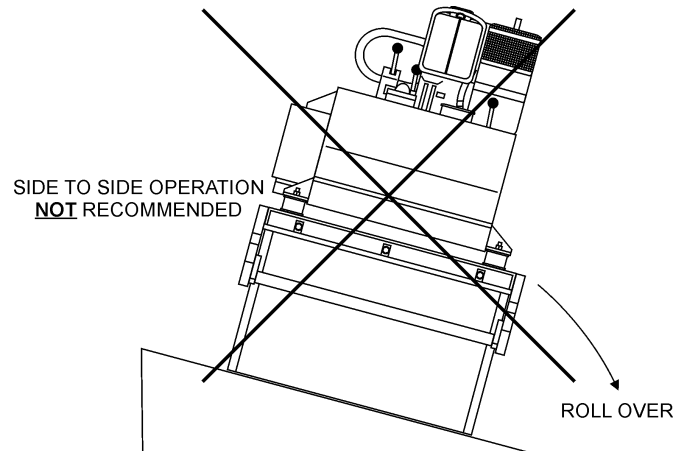


Figure 5. Recommended Slope

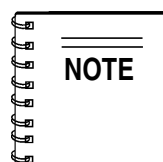
In the event the roller does tip over, extreme care must be taken to prevent damage to the engine. When the roller has been tipped over, oil from the engine crankcase can flow into the combustion chamber, which can severely damage the engine the next time it is started.

**IMMEDIATELY** after a unit has tipped over upright the unit as soon as possible to prevent oil from leaking into the combustion chamber.

## CAUTION :

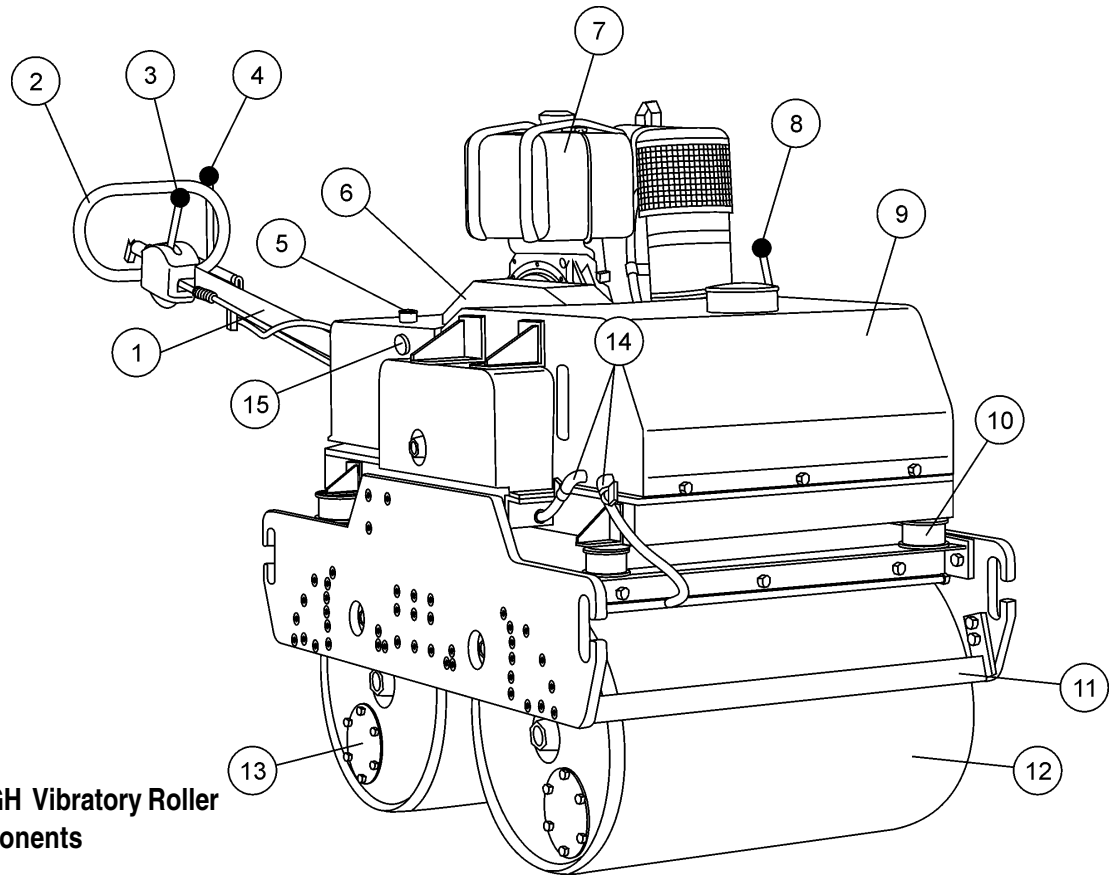


To prevent damage to the engine after a rollover, the unit must **NOT** be started. **NEVER** start a unit after a rollover. **CONTACT** your nearest authorized Multiquip dealer for instructions or servicing.



**NEVER!** operate the roller on *side slopes*. The roller may tip over causing injury to personnel and severe damage to the equipment

# MDR-9GH — VIBRATORY ROLLER COMPONENTS



**Figure 6. MDR-9GH Vibratory Roller Components**

Figure 6 illustrates the location of the major components for the MDR-9GH Vibratory Roller. The function of each component is described below:

1. **Handle Bar** – When operating the roller, this handle is to be in the downward position. When the roller is to be **stored**, move the handle bar to the upright position.
2. **Hand Grip** – When operating the roller, use this hand grip to maneuver the roller. Also has dead man device, when pressed or hit while traveling in reverse, causes the travel lever to return to neutral position to stop the machine.
3. **Travel Lever** – **Push** the lever forward, the roller will move in a forward direction, **pull** the lever backwards, the roller will move in backwards direction. Placing the lever in the middle (midway) will cause the roller not to move (neutral).
4. **Vibrator Lever** – Turns the vibration on and off.
5. **Oil Cap** – Open to fill with proper grade of diesel engine oil.
6. **V-Belt Cover** – Remove this cover to gain access to the V-belts. **NEVER** run the vibratory roller without the V-belt cover. If the V-belt cover is not installed, the possibility exist that your hand may get caught between the V-belt and clutch, thus causing serious injury and bodily harm.
7. **Engine** – This vibratory roller uses a **HONDA GX340KQAE2** gasoline engine. Refer to the owner's manual for engine information and related topics.
8. **Vibrator Lever (on the body of machine)** – Turns the vibration on and off.
9. **Water Tank** – Holds 6 gallons (23 liters) of water for the sprinkler system.
10. **Shock Absorber** -
11. **Scraper Bar** – This bar helps prevent buildup of material between the drum and the frame.
12. **Vibration Rollers** – 18-inch diameter steel drums that provide the compaction force in the compaction and patching of asphalt-type surfaces.
13. **Checking Cover for Chains** – Take off the cover to check and lubricate chains.
14. **Water Valves**– Turn on the water sprinkling system.
15. **Hydraulic Oil Gauge** – Indicates the hydraulic oil level.



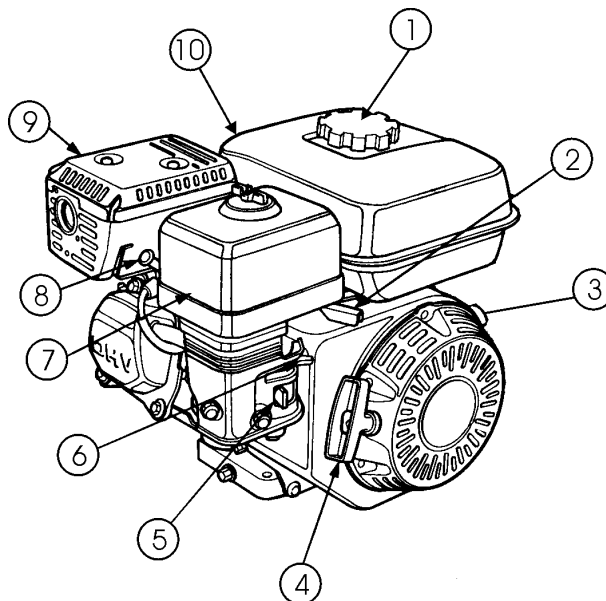


Figure 7. HONDA GX340KQAE2 Engine Components

## INITIAL SERVICING

The engine (Figure 7) must be checked for proper lubrication and filled with fuel prior to operation. Refer to the manufacturer's engine manual for instructions & details of operation and servicing. The engine shown above is a **HONDA** engine, operation for other types of engines may vary somewhat.

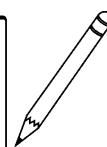
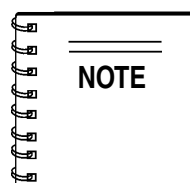
1. **Fuel Filler Cap** – Remove this cap to add unleaded gasoline to the fuel tank. Make sure cap is tightened securely. **DO NOT** over fill.



Adding fuel to the tank should be done only when the engine is stopped and has had an opportunity to cool down. In the event of a fuel spill, **DO NOT** attempt to start the engine until the fuel residue has been completely wiped up, and the area surrounding the engine is dry.

2. **Throttle Lever** – Used to adjust engine RPM speed (lever advanced forward **SLOW**, lever back toward operator **FAST**).
3. **Engine ON/OFF Switch** – ON position permits engine starting, OFF position stops engine operations.
4. **Recoil Starter (pull rope)** – Manual-starting method. Pull the starter grip until resistance is felt, then pull briskly and smoothly.
5. **Fuel Valve Lever** – **OPEN** to let fuel flow, **CLOSE** to stop the flow of fuel.

6. **Choke Lever** – Used in the starting of a cold engine, or in cold weather conditions. The choke enriches the fuel mixture.
7. **Air Cleaner** – Prevents dirt and other debris from entering the fuel system. Remove wing-nut on top of air filter canister to gain access to filter element.



Operating the engine without an air filter, with a damaged air filter, or a filter in need of replacement will allow dirt to enter the engine, causing rapid engine wear.

8. **Spark Plug** – Provides spark to the ignition system. Set spark plug gap to 0.6 - 0.7 mm (0.028 - 0.031 inch) Clean spark plug once a week.
9. **Muffler** – Used to reduce noise and emissions.



Engine components can generate extreme heat. To prevent burns, **DO NOT** touch these areas while the engine is running or immediately after operating. **NEVER** operate the engine with the muffler removed.

10. **Fuel Tank** – Holds unleaded gasoline. For additional information refer to engine owner's manual.

## CAUTION :



Never operate the vibratory roller in a confined area or enclosed structure that does not provide ample *free flow of air*.



**ALWAYS** wear approved eye and hearing protection before operating the vibratory roller.



## BEFORE STARTING

1. Read safety instructions at the beginning of manual.
2. Familiarize yourself with the operating and control elements of the machine and the working environment. This includes obstacles in the working area, bearing capacity of the ground and the necessary safety provisions.
3. Check the air filter for dirt and dust. If the air filter is dirty, replace air filter with a new one as required.
4. Check fastening nuts and bolts for tightness. Loose threads may cause damage to the machine when vibrating.
5. Understand the geographical features and regulations of the job site.
6. Clean the vibratory roller, removing dirt and dust, particularly, the bottom of the plate, engine cooling air inlet.



## CHECKING ENGINE OIL LEVEL

1. Make sure that the machine is situated in a flat surface so that level measurements will be accurate.
2. Pull out the dipstick from the oil tank (Figure 8).

## CAUTION :



**DO NOT** overfill oil tank. This could cause oil leaks and sluggish operation. Clean cap and surrounding area before opening to prevent dirt from entering tank.

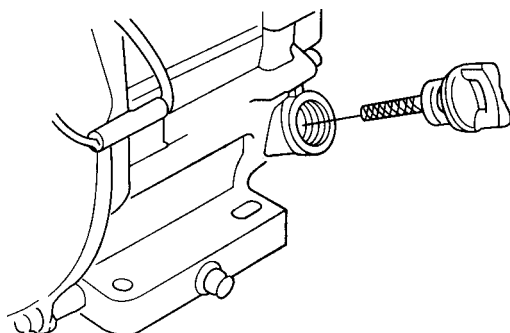


Figure 8. Oil Dipstick

3. If the oil level is low, fill to the edge of the oil filler hole with the recommended oil type (Table 4). Maximum oil capacity is 1.6 quarts (1.1 liters).

TABLE 4. OIL TYPE

Season	Temperature	Oil Type
Summer	25°C or Higher	SAE 10W-30
Spring/Fall	25°C~10°C	SAE 10W-30/20
Winter	0°C or Lower	SAE 10W-10



**Explosive Fuel**

## DANGER



Diesel fuel is highly flammable and can be dangerous if mishandled. **DO NOT** smoke while refueling. **DO NOT** attempt to refuel the vibratory roller if the engine is *hot!* or *running*.

## CHECKING FUEL

1. Remove the fuel cap located on top of fuel tank.
2. Visually inspect to see if fuel level is low. If fuel is low, replenish with diesel fuel (Figure 9).
3. When refueling, be sure to use a strainer for filtration. **DO NOT** top-off fuel. Wipe up any spilled fuel.

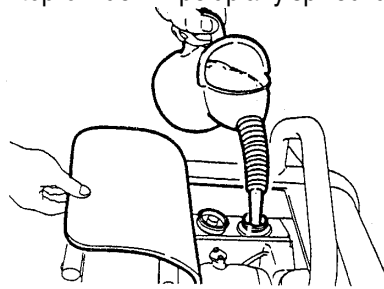


Figure 9. Refueling

## DANGER



Fuel spillage on a hot engine can cause a **fire** or **explosion**. If fuel spillage occurs, wipe up the spilled fuel completely to prevent fire hazards. **NEVER!** smoke around or near the roller.



## CHECKING HYDRAULIC SYSTEM

1. Check the oil tank level gauge (Figure 10). Oil level should be at the middle indication of the gauge or higher. Fill as required
2. Check the surroundings of the oil tank, hydraulic pump and motor for oil leakage.

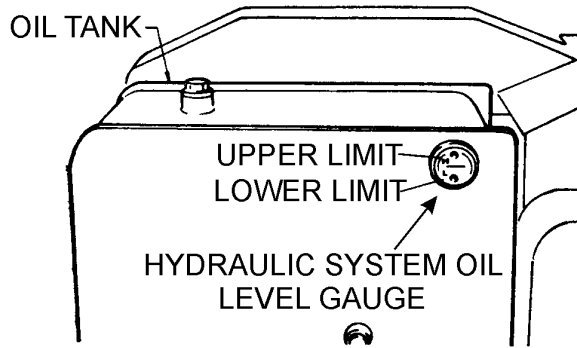


Figure 10. Hydraulic System Oil Level Gauge

## DANGER



**ALWAYS** keep hands and fingers away from pinch points. **DO NOT** allow anyone to reach in on dangerous sections of the machine to avoid any accidents.

## CHECKING THE V-BELT

1. Check all bolts and screws and make sure all are securely tightened.
2. Check V-belt for proper tension. The normal slack should be approximately 1/8 inch (3 to 5 mm) when the belts are forcibly depressed between the two sheaves (Figure 11). Insufficient tension causes weak vibration and machine damage.

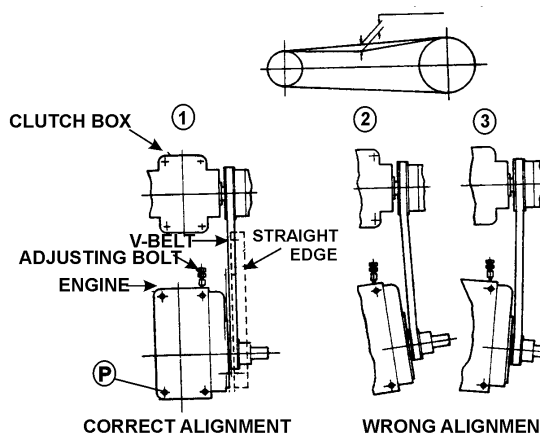


Figure 11. V-Belt Tension

## CHECKING THE CLUTCH BOX OIL LEVEL

1. Check clutch box for any oil leakage.
2. Remove the level plug and check oil level (Figure 12).
3. Add oil if necessary.

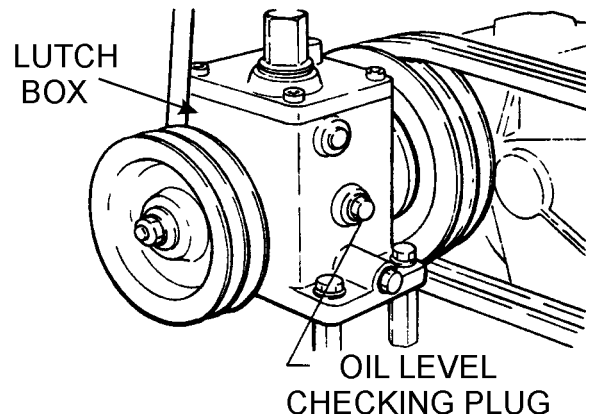


Figure 12. Clutch Box Oil Level Check

## CHECKING THE VIBRATOR OIL LEVEL

1. Remove the red filler plug and the oil level inspection hole plug from the vibrator case (Figure 13).
2. Fill with oil until oil overflows from inspection hole.

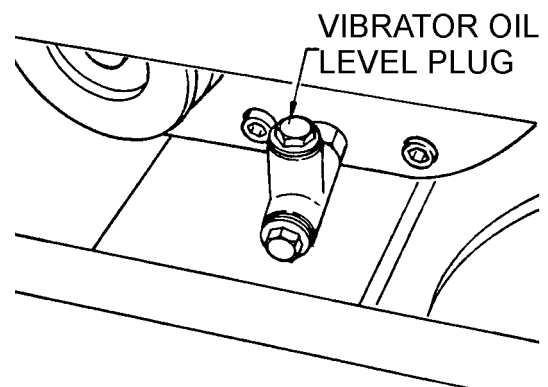


Figure 13. Vibrator Oil Level Check

## CHECKING WATER TANK

1. Check the water tank to see if filled. Add water if necessary. The water tank has a capacity of approximately 6 gallons (23 liters) (Figure 14).

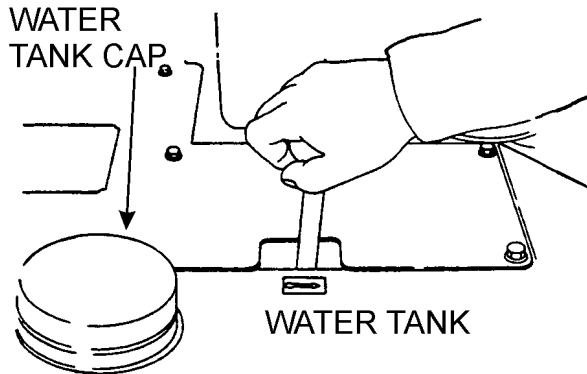


Figure 14. Water Tank Check

## CAUTION :



Be careful not to confuse the water tank with the oil tank.

## CHECKING LEVERS

1. Check travel and vibrator levers to make sure they are functioning properly (Figure 6).
2. With travel lever placed in reverse, push the deadman device and verify that the travel lever returns to neutral position. The travel lever stays in neutral position once the deadman device is released.

## CHECKING SCRAPER BAR

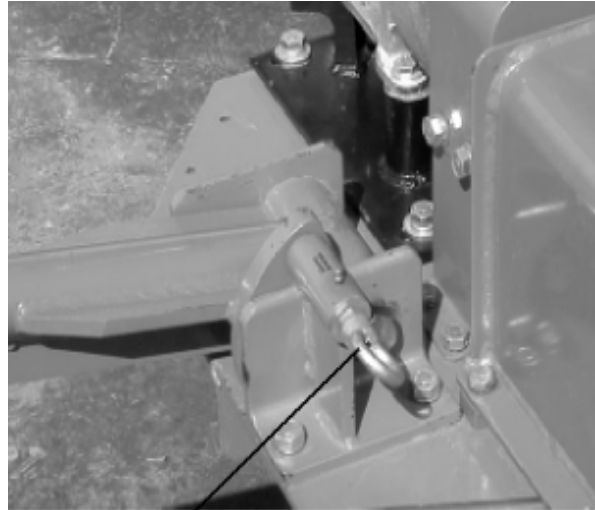
1. Check scraper bar and make sure that they are not clogged with mud, bent or damaged (Figure 6).
2. Adjust clearance between drums and scrapers as necessary.

## CHECKING BOLTS, NUTS, AND SCREWS

1. Check bolts, nuts, and screws on various parts of the machine, including the engine, for proper tightness.

## POSITIONING THE HANDLE BAR

1. Release the handle bar release pin (Figure 15) and position the handle bar to the lowered position before starting operation.
2. When machine is not in use, release the handle bar release pin and position the handle bar to the upright position.



Handle Bar Release Pin

Figure 15. Handle Bar Positioning

## INITIAL STARTUP (ENGINE)

### Recoil Start

1. Place the **fuel valve lever** (Figure 16) to the "ON" position.

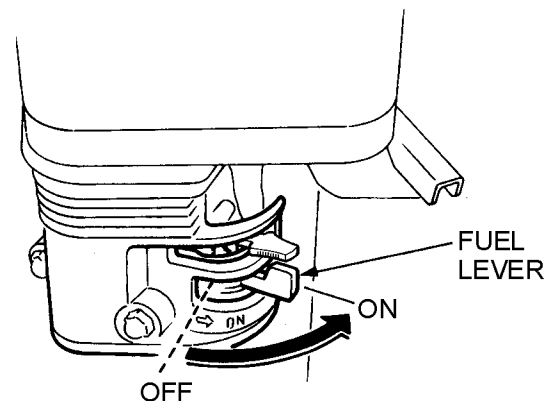


Figure 16. Engine Fuel Valve Lever

- Place the **Engine ON/OFF switch** (Figure 17) in the "ON" position.

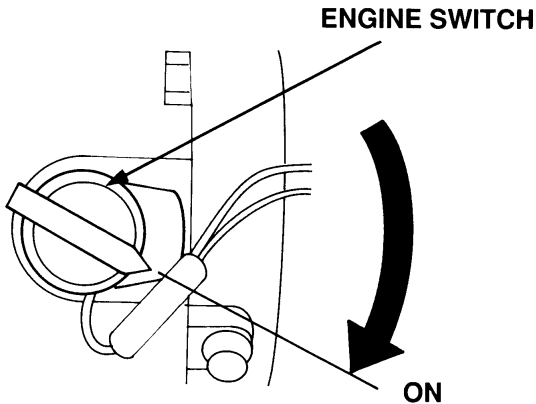
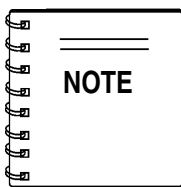


Figure 17. Engine ON/OFF Switch



The **CLOSED** position of the choke lever enriches the fuel mixture for starting a **COLD** engine. The **OPEN** position provides the correct fuel mixture for normal operation after starting, and for restarting a warm engine.

- Place the **Choke Lever** (Figure 18) in the "**CLOSED**" position.

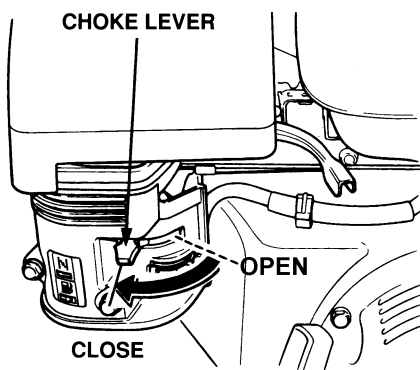


Figure 18. Choke Lever

## CAUTION



The engine speed has been set at the factory. Changing the governor speed could damage the vibratory roller.



- Rotate the **throttle lever** (Figure 19) halfway between **fast** and **slow** for starting. The engine governor speed is factory set to ensure optimum operating speeds.

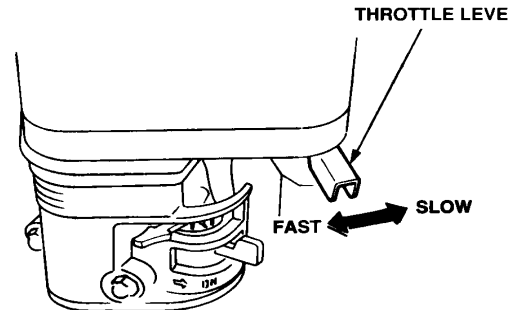


Figure 19. Throttle Lever

- Grasp the starter grip (Figure 20) and slowly pull it out. The resistance becomes the hardest at a certain position, corresponding to the compression point. Pull the starter grip briskly and smoothly for starting.

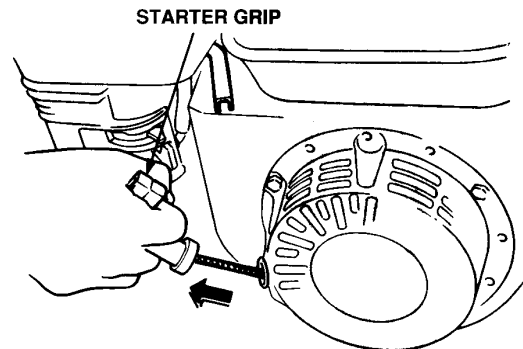


Figure 20. Starter Grip

## CAUTION



**DO NOT** pull the starter rope all the way to the end. **DO NOT** release the starter rope after pulling. Allow it to rewind as soon as possible.

### Electric Start

- Turn the key to the "**START**" position until the engine starts. If the engine fails to start within 5 seconds, release the key, and wait at least 10 seconds before operating the starter again.

## TRAVELING CAUTION :



Make sure to follow all safety rules referenced in the safety section of this manual before operating roller. Keep work area clear of debris and other objects that could cause damage to the roller or bodily injury.

1. To make the roller move in the forward direction push the travel lever ( Figure 21) forward. This roller has a hydraulic variable speed transmission. By moving the travel lever various increments, you can vary the speed from 0 to 1.8 mph (0 to 3 km/hr).

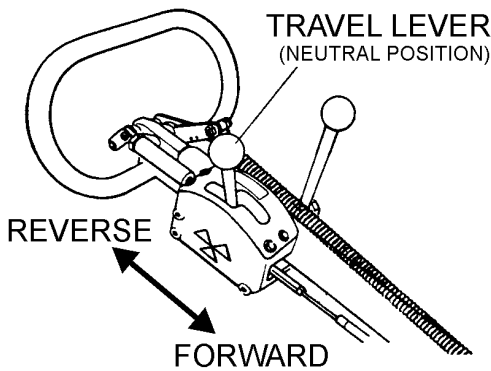


Figure 21. Travel Lever

2. To make the roller move in the reverse direction pull the travel lever ( Figure 21) backwards.
3. Firmly grasp the roller's hand grip, the roller will begin moving in the desired position when the direction lever has been placed in the desired position.

## CAUTION :



**DO NOT** reduce speed during work. When shifting travel lever from forward to reverse, be sure to stop the lever at the neutral position first before moving the lever to the opposite direction. **DO NOT** shift the lever from forward to reverse (or reverse to forward) in one motion.

## CAUTION :



After test travel, shut down engine and check for any problems including oil leakage. If any trouble is found, correct the problem before attempting to operate the roller again.

## VIBRATING

1. Shift the two vibrator levers ( Figures 22 and 23) to the vibrate position to start vibrations.

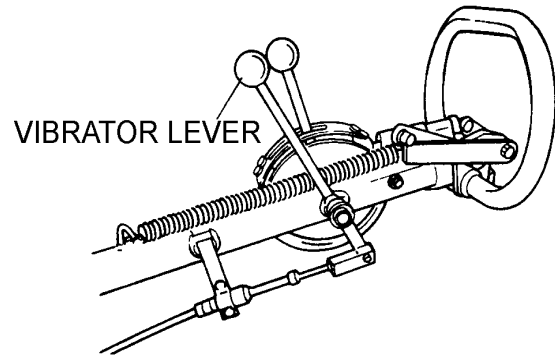


Figure 22. Vibrator Lever

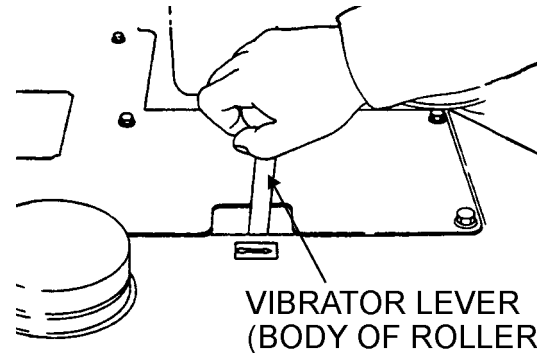


Figure 23. Vibrator Lever (Body)

## CAUTION :



Using vibration with clutch slipping causes the clutch to burn. Also, vibration should **NOT** be used over completely compacted area, paved road surface, or with stationary roller.

## WATERING

1. To operate water sprinkling system, turn on the front and rear water valves on the side of the roller. (Figure 24).

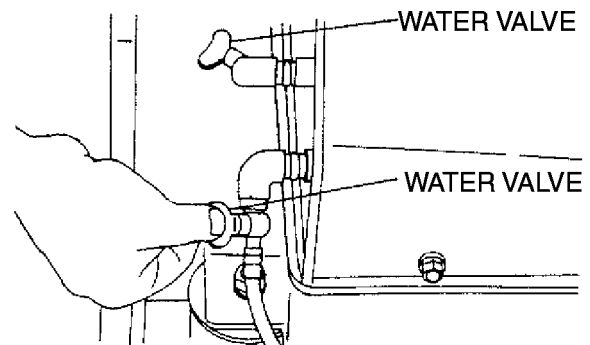


Figure 24. Water Valves

## STOPPING

1. Place the vibrator and travel levers to the neutral position.
2. Slow down the engine and allow to cool for at least 2 minutes. In an electric start, return the key switch to the STOP position as soon as the engine stops.

## CAUTION :



Neglecting to return the key switch to the STOP position will cause the battery to discharge, making start-up impossible the next time.

3. After the engine stops, close the fuel cock.
4. The hydraulic brake is automatically engaged when the travel lever is in neutral position. When parked on a slope with the engine turned off, place a block against the roller drum to prevent the roller from moving.

## UNLOADING

1. If you need to move the roller by pushing it manually once engine is stopped, push in the upper and lower knobs of the transmission check valve. This will cause the hydraulic break to disengage and allow the roller to be moved without causing damage (Figure 25).

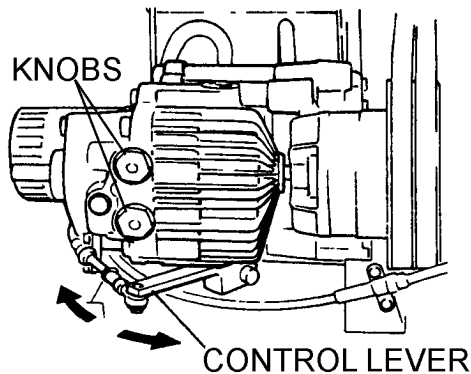


Figure 25. Disengaging Hydraulic Brake

2. After moving, reset upper and lower knobs.

## CAUTION :



**NEVER** tow roller with any type of vehicle. Doing so will damage the hydraulic system.

**NEVER** perform unloading procedure on a slope. This may cause roller to roll down if parking brake or blocking is deficient.

## LIFTING

1. Use a crane or lift to load and unload the machine. A skilled crane operator is required to perform the job.
2. When lifting the machine, check for any damaged or loose bolts, lifting hooks, and shock mounts.
3. Check any damaged or loose bolts in the guard frame to avoid machine sliding off.
4. Make sure that the machine is shut off before machine is lifted.
5. Use reliable cable for lifting.
6. Always lift the machine vertically and keep the machine away from workers and animals.
7. Do not lift the machine higher than the required height.

## TRANSPORTING

1. Always make sure that the machine is shut off while being transported.
2. Check that the fuel cap is properly closed and tightened.
3. When traveling long distances or on rugged terrain, drain the fuel of the machine before transporting.
4. Tie down the machine securely on the transportation so that it will not move or topple over.

## CAUTION:



Inspection and other services should **always** be carried out on hard and level ground with the engine shutdown.

### INSPECTION AND MAINTENANCE SERVICE TABLES

- To make sure your plate vibratory roller is always in good working condition before using, carry out the maintenance inspection in accordance with Tables 4 through 6.

**TABLE 5. MDR-9GH MACHINE INSPECTION**

ITEM	HOURS OF OPERATION	REMARKS
Loose or Missing Screws	Every 8 hours (every day)	
Damaged Parts	Every 8 hours (every day)	
Function of Controlling System Part	Every 8 hours (every day)	
Chain Tension Adjustment	Every 50 hours	See page 26
Hydraulic Oil Filter Replacement	Initially after 25 hours, then every 250 hours (2 months), every 500 hours (4 months), every 1,000 hours thereafter.	See page 28
Hydraulic Oil Check	Initially, every 4 to 5 hours. After one week, twice a day. After 2 weeks, once a day.	See page 27
Hydraulic Oil Replacement	Every 1,000 to 1,500 hours	See page 27
Vibration Clutch Check	As necessary	See page 27

## CAUTION:



These inspection intervals are for operation under normal conditions. Adjust your inspection intervals based on the number hours vibratory roller is in use, and particular working conditions.

## CAUTION:



Fuel piping and connections should be replaced every 2 years.

**TABLE 6. MDR-9GH ENGINE CHECK**

ITEM	HOURS OF OPERATION
Oil or Fuel Leak	Every 8 hours (every day)
Tightness of Fastening Threads	Every 8 hours (every day)
Engine Oil Check and Replenishment	Every 8 hours (every day) (Replenish to specified maximum level)
Engine Oil Replacement	After first 25 hours then every 50 to 100 hours
Air Filter Cleaning	Every 100 hours
See separate engine manual for details on engine check.	

### DAILY SERVICE

- Check for leakage of fuel or oil.
- Check for loose screws including tightness. See Table 6 below (tightening torque), for retightening:

**TABLE 7. TIGHTENING TORQUE (in. kg/cm) DIAMETER**

Material	6mm	8mm	10mm	12mm	14mm	16mm	18mm	20mm
4T	70	150	300	500	750	1,100	1,400	2,000
6-8T	100	250	500	800	1,300	2,000	2,700	3,800
11T	150	400	800	1,200	2,000	2,900	4,200	5,600
*	100	300~350	650 ~ 700					

\* (In case counter-part is of aluminum)  
(Threads in use with this machine are all right handed)  
Material and quality of material is marked on each bolt, and screw.

- Remove soil and clean the bottom of roller.
- Check the levers, cables and linkage.
- Check engine oil.



## SPARK PLUG

1. Remove and clean the spark plug (Figure 26).
2. Adjust the spark gap to 0.028 ~0.031 inch (0.6~0.7 mm). This unit has electronic ignition, which requires no adjustments.

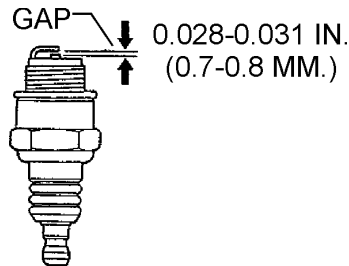


Figure 26. Spark Plug Gap

## ENGINE OIL REPLACEMENT

1. Replace engine oil, first in 25 hours of operation and every 50 to 100 hours afterwards.
2. Drain the engine oil when the oil is **warm** as shown in Figure 27.
3. Remove the oil drain bolt and sealing washer and allow the oil to drain into a suitable container.
4. Replace engine oil with recommended type oil as listed in Table 3. Engine oil capacity is 1.16 quarts (1.1 liters). **DO NOT** overfill.
5. Install drain bolt with sealing washer and tighten securely.

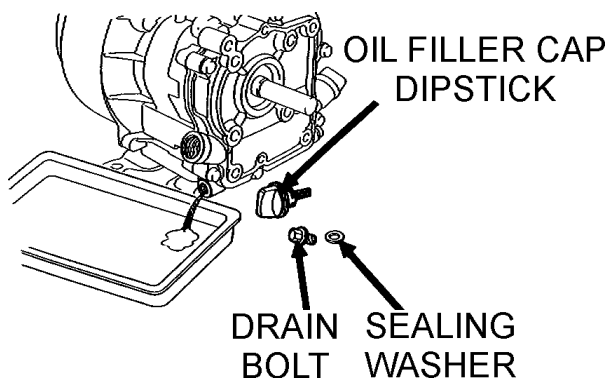


Figure 27. Engine Oil (Draining)

## AIR FILTER

1. Remove the air cleaner cover and foam filter element as shown in Figure 28.
2. Tap the paper filter element (Figure 28) several times on a hard surface to remove dirt, or blow compressed air [not exceeding 30 psi (207 kPa, 2.1 kgf/cm<sup>2</sup>)] through the filter element from the air cleaner case side. **NEVER** brush off dirt. Brushing will force dirt into the fibers. Replace the paper filter element if it is excessively dirty.
3. Clean foam element in warm, soapy water or nonflammable solvent. Rinse and dry thoroughly. Dip the element in clean engine oil and completely squeeze out the excess oil from the element before installing.

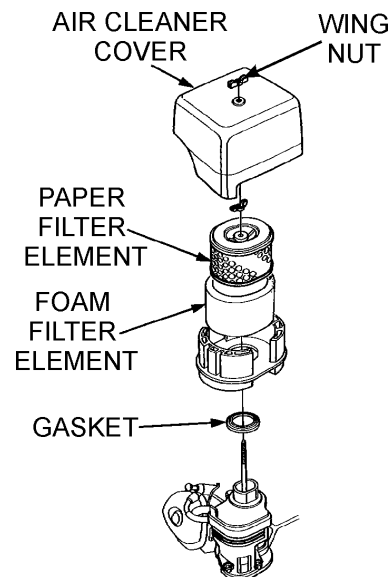
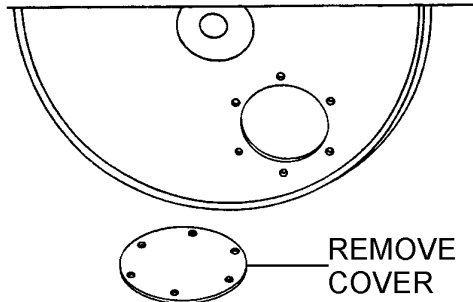


Figure 28. Engine Air Filter

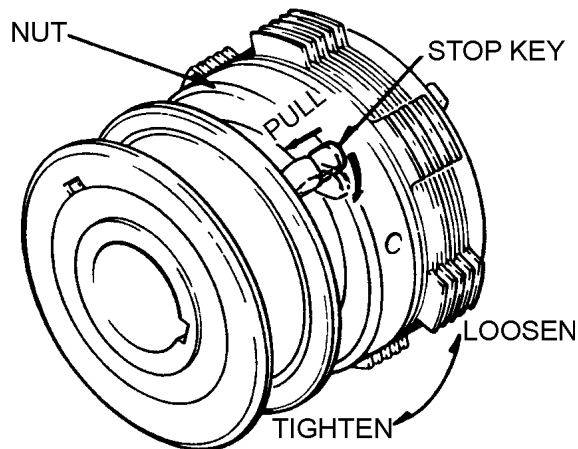
## CHECKING THE CHAINS

1. Take off the checking cover on roller and coat grease on the chain if necessary (Figure 29). The chain should be lightly lubricated with motor oil.



**Figure 29. Chain Cover**

2. Check the chain tension and if loose, adjust the chain tension with the tightener (Figure 30). Chain tension should be adjusted every 50 hours of operation.

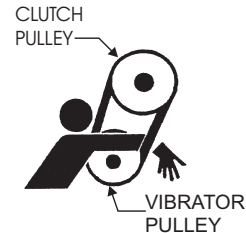


**Figure 30. Chain Tightener**

## CAUTION:



**NEVER** attempt to check the V-belt with the engine running. Severe injury can occur if your hand gets caught between the V-belt and the clutch (Figure 31). Always use safety gloves.



**Figure 31. V-Belt Hazard**

## VIBRATION CLUTCH ADJUSTMENT

1. Remove the protective cover from the clutch by removing the 4 allen screws.
2. Pull out the stop key and turn to the release position (Figure 30).
3. Viewing the clutch from the shifter-pulley side: if the clutch nut is turned to the right, the clearance between the adjusting and pressure plate decreases as the amount of torque increases. Normal adjustment is from 1 to 2 notches.
4. Make sure that the shifting lever is not too stiff. Lever should engage with moderate pressure.
5. After adjustment, return the stop key to the locked position.

## HYDRAULIC OIL CHECK

1. Check for any oil leakage from the hoses and joints daily.
2. Check hydraulic oil level every 4 to 5 hours after starting operation.
3. After one week of operation, check hydraulic level twice a day .
4. After two weeks of operation, check hydraulic level once a day .
5. Replace hydraulic oil after first 200 hours and in every 1,000 hours of operation.

## CAUTION:



Make sure hydraulic oil is at a normal safe operating level. **DO NOT** over fill.

## REPLACING HYDRAULIC OIL

1. Change the hydraulic oil every 1,000 to 1,500 hours of operation. Change the hydraulic oil more often in high ambient temperature operation.
2. Remove the drain plug and hose tank and drain the hydraulic oil.
3. Reinstall the drain plug to the oil tank.
4. Open the tank cap (Figure 32) and fill tank with hydraulic oil. (Capacity: About 4.5 gallons). Use **Shell Tellus Oil #46** or equivalent.

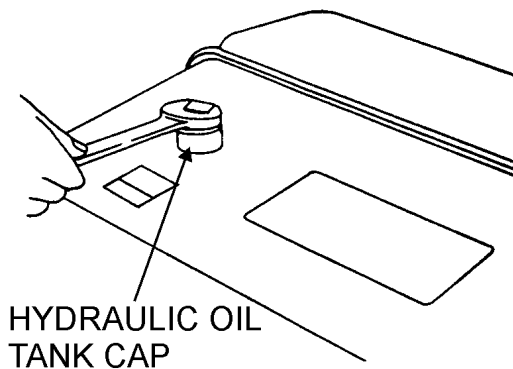


Figure 32. Hydraulic Oil Change

5. After filling tank, tighten the tank cap firmly with a wrench.

## CAUTION:

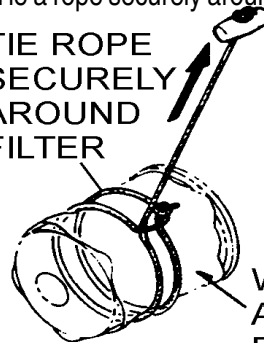


Make sure that dust , water, and other foreign objects do not enter tank. It is recommended to filter the oil through a cloth.

## HYDRAULIC OIL FILTER CHECK

1. The hydraulic oil filter should be replaced after first 25 hours of operation.
2. After first replacement, it should be replaced after 250 hours operation (2 months), every 500 hours of operation (4 months), and every 1,000 hours of operation thereafter.
3. When the suction resistance exceeds 254 mmHg (oil temperature in operation is 140 degrees F), replace filter.
4. To remove the oil filter, wind a cloth around the filter to prevent slipping (Figure 33).
5. Tie a rope securely around the filter (Figure 33).

TIE ROPE  
SECURELY  
AROUND  
FILTER



WIND CLOTH  
AROUND THE  
FILTER TO  
PREVENT  
SLIPPING

Figure 33. Cloth and Rope Around Filter

6. Forcibly pull the rope to remove the filter (Figure 34).

PULL ROPE  
TO REMOVE  
FILTER

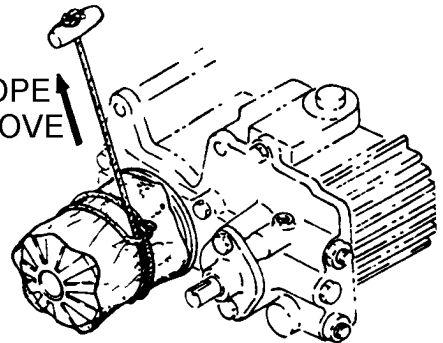
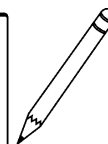
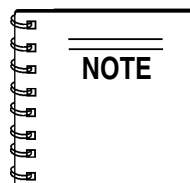


Figure 34. Filter Removal

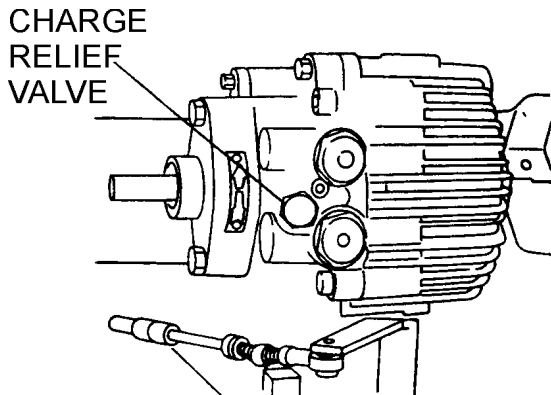
7. Immediately replace with new filter, screwing it on by hand to avoid hydraulic oil leak.



Use only genuine Mikasa replacement oil filters (10 micron filter paper. Do not use automobile-type oil filters.

## HYDRAULIC AIR EXTRACTION

1. After filling hydraulic oil tank with oil, loosen the oil hose joint and check that oil is enough to reach the oil suction and outlet ports in the hydraulic transmission. Tighten the hose joint securely after checking.
2. Loosen the charge relief valve located on the front side of the hydraulic transmission (Figure 35).



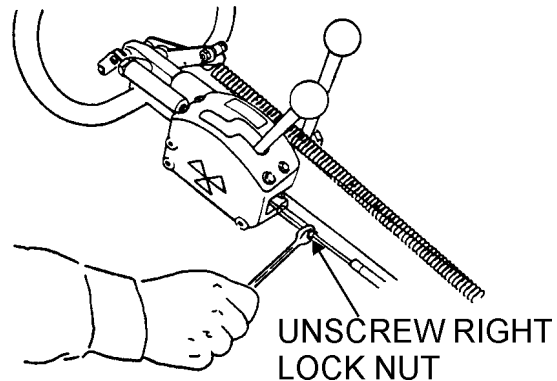
**Figure 35. Loosening Charge Relief Valve**

3. Check that oil flows out from the valve hole.
4. Replace the charge relief valve tightly.
5. With the travel and vibrator levers in neutral position, start the engine and idle at low speed for 3 to 5 minutes.
6. Check the forward and reverse rotation of the output shaft by moving the travel lever slowly to its forward and reverse positions.
7. Check the oil level gauge and make sure that there are no air bubbles mixed in the oil. After checking, operate the roller slowly at first then at full speed.
8. When oil level in the tank is low, replenish oil up to the specified level, and screw the cap securely with a wrench.
9. If bubbles remain in the oil or foam is found, air is being sucked through the suction side and should be checked.

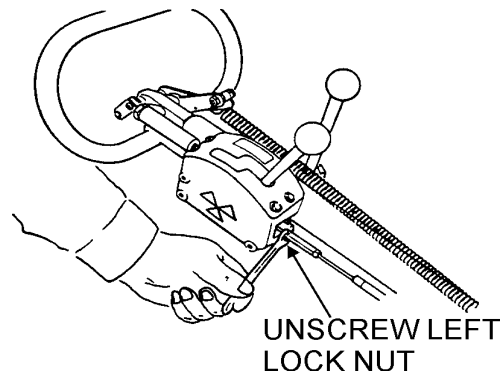
## NEUTRAL POSITION ADJUSTMENT

Once the travel lever has been set to neutral position with the engine running, the hydraulic brake is operating and the roller should not move. If the roller inches forward or backwards with the lever in the neutral position, turn-buckle of the cable should be adjusted as follows:

1. Stop the engine and set the travel lever in the neutral position.
2. Unscrew the two lock nuts on the sides of the cable (Figures 36 and 37).

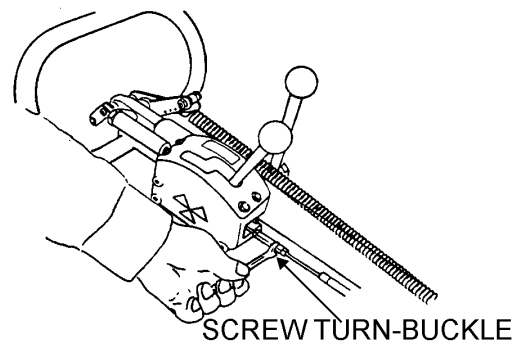


**Figure 36. Unscrewing Right Lock Nut**



**Figure 37. Unscrewing Left Lock Nut**

3. If the machine moves forward, screw the turn-buckle clockwise. If the machine moves backwards, screw the turn-buckle counterclockwise (Figure 38).
4. Screw back the lock nuts on the turn-buckle.
5. Start the engine and make sure that the roller does not inch forward or backward at the neutral position of the travel lever.



**Figure 38. Adjusting the Turn-Buckle**

If the neutral position of the travel lever and the neutral point of transmission do not match after adjustment is repeated, align as follows:

1. Loosen the hex socket head bolt M10 used for mounting the control lever on the underside of the transmission (Figure 39).
2. For forward movement, move the control lever slightly to the left.
3. For backwards movement, move the control lever slightly to the right.

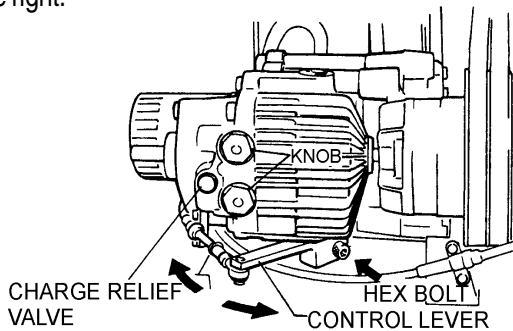


Figure 39. Unscrewing Left Lock Nut

## BATTERY MAINTENANCE DANGER :



Lead-acid battery contains sulfuric acid, which may damage eyes or skin on contact.



### FOR YOUR SAFETY:

- **ALWAYS** wear a face shield to avoid acid getting into the eyes. If acid gets in contact with eyes, flush immediately with clean water and get medical advice.
- Wear rubber gloves and protective clothes to keep acid off skin. If acid gets in contact with skin, wash off immediately with clean water.
- Use a flashlight to check battery electrolyte level. **ALWAYS** check the engine is stopped.
- **DO NOT** charge battery or jump-start engine when the battery is frozen. Warm the battery to 15 degrees F or battery may explode.
- Replace the battery with the same or similar capacity battery or battery may explode.

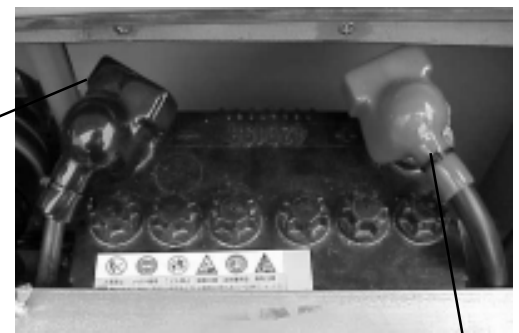
- **DO NOT** close the exhaust outlet of battery. The gas pressure building up in the battery may cause explosion.
- Before using a battery charger, read and understand the charger instruction manual thoroughly.
- Charge the battery in a non-spark, well-ventilated area. Avoid fire from cigarette sparks or matches.

1. If a battery has not been used for some time, reduce the charge level initially to protect each plate inside the battery.
2. Check the battery terminals periodically to ensure that they are in good condition.
3. Use wire brush or sand paper to clean the battery terminals.
4. Check battery for cracks or any other damage. If white pattern appears inside the battery or paste has accumulated at the bottom, replace the battery.
5. Measure the specific gravity of electrolyte:
  - completely charged: 1.270 - 1.290
  - needs charging: 1.260 or lower
6. If the machine will not be in operation for a long period of time, charge the battery sufficiently, tighten all caps, correctly, store in cool dry place and check the battery charge level every month to maintain the performance of the battery.

### BATTERY CABLE CONNECTION

1. When removing cable, disconnect the ground side (normally negative) first (Figure 40).

Negative Terminal



Positive Terminal

Figure 40. Battery Connection

2. When installing cable connect the ground side (normally negative) last.

# MDR-9GH — ENGINE TROUBLESHOOTING

Practically all breakdowns can be prevented by proper handling and maintenance inspections, but in the event of a breakdown, please take a remedial action following the diagnosis based on the Engine Troubleshooting (Table 8) information shown below and on the proceeding page. If the problem cannot be remedied, please leave the unit just as it is and consult our company's business office or service plant.

**TABLE 8. ENGINE TROUBLESHOOTING**

SYMPTOM	POSSIBLE CAUSE	SOLUTION
Difficult to start, "fuel is available, but no SPARK at spark plug".	Spark plug bridging?	Check gap, insulation or replace spark plug.
	Carbon deposit on spark plug?	Clean or replace spark plug.
	Short circuit due to deficient spark plug insulation?	Check spark plug insulation, replace if worn.
	Improper spark plug gap?	Set to proper gap.
Difficult to start, "fuel is available, and SPARK is present at the spark plug".	ON/OFF switch is shorted?	Check switch wiring, replace switch.
	Ignition coil defective?	Replace ignition coil.
	Improper spark gap, points dirty?	Set correct spark gap and clean points.
	Condenser insulation worn or short circuiting?	Replace condenser.
	Spark plug wire broken or short circuiting?	Replace defective spark plug wiring.
Difficult to start, "fuel is available, spark is present and compression is normal"	Wrong fuel type?	Flush fuel system, and replace with correct type of fuel.
	Water or dust in fuel system?	Flush fuel system.
	Air cleaner dirty?	Clean or replace air cleaner.
Difficult to start, "fuel is available, spark is present and compression is low"	Suction/exhaust valve stuck or protruded?	Re-seat valves.
	Piston ring and/or cylinder worn?	Replace piston rings and or piston.
	Cylinder head and/or spark plug not tightened properly?	Torque cylinder head bolts and spark plug.
	Head gasket and/or spark plug gasket damaged?	Replace head and spark plug gaskets.
No fuel present at carburetor.	Fuel not available in fuel tank?	Fill with correct type of fuel.
	Fuel cock does not open properly?	Apply lubricant to loosen fuel cock lever, replace if necessary.
	Fuel filter clogged?	Replace fuel filter.
	Fuel tank cap breather hole clogged?	Clean or replace fuel tank cap.
	Air in fuel line?	Bleed fuel line.

**TABLE 8. ENGINE TROUBLESHOOTING (CONTINUED)**

SYMPTOM	POSSIBLE CAUSE	SOLUTION
"Weak in power" compression is proper and does not misfire.	Air cleaner not clean?	Clean or replace air cleaner
	Improper level in carburetor?	Check float adjustment, re-build carburetor.
	Defective Spark plug?	Clean or replace spark plug.
	Defective Spark plug?	
"Weak in power" compression is proper but misfires.	Water in fuel system?	Flush fuel system, and replace with correct type of fuel.
	Dirty spark plug?	Clean or replace spark plug.
	Ignition coil defective?	Replace ignition coil.
Engine overheats.	Spark plug heat value improper?	Replace with correct type of spark plug.
	Correct type of fuel?	Replace with correct type of fuel
	Cooling fins dirty?	Clean cooling fins.
Rotational speed fluctuates.	Governor adjusted correctly?	Adjust governor.
	Governor spring defective?	Replace governor spring.
	Fuel flow restricted?	Check entire fuel system for leaks or clogs.
Recoil starter malfunction.	Recoil mechanism clogged with dust and dirt?	Clean recoil assembly with soap and water.
	Spiral spring loose?	Replace spiral spring.

## MDR-9GH — ROLLER TROUBLESHOOTING

Practically all breakdowns can be prevented by proper handling and maintenance inspections, but in the event of a breakdown, please take a remedial action following the diagnosis based on the Roller Troubleshooting (Table 9) information shown below and on the proceeding page. If the problem cannot be remedied, please leave the unit just as it is and consult our company's business office or service plant.

**TABLE 9. ROLLER TROUBLESHOOTING**

SYMPTOM	POSSIBLE PROBLEM	SOLUTION
Unit does not travel or travel is not smooth.	Defective centrifugal clutch?	Repair or replace clutch.
	Damaged rubber coupling and flange?	Replace rubber coupling and flange.
	Defective travel cable and link?	Repair or replacetravel cable and link.
	Damaged scraper or too much mud in scraper?	Replace or repair scraper.
	Damaged or clogged oil filter?	Replace filter.
	Damaged or leaking hydraulic pipe?	Repair or replace parts.
	Low oil level or contaminated oil?	Replenish or replace oil.
	Damaged or leaking hydraulic transmission?	Repair or replace hydraulic pump.
	Damaged or leaking hydraulic transmission?	Repair or replace hydraulic motor.
	Damaged drum gear and bearing?	Repair parts.
	Bad drum rotation?	Repair or replace drum.
Unit does not vibrate or has weak vibration.	Defective centrifugal clutch?	Repair or replace clutch.
	Damaged or slipping V-belt?	Replace V-belt or adjust tension.
	Damaged vibration cable and linkage?	Replace or repair vibration cable and linkage.
	Damaged vibration clutch?	Adjust or replace clutch.
	Defective clutch vibrator pulley V-belt?	Replace V-belt.
	Vibrator does not turn smoothly with hand?	Check and repair vibrator. Check if oil level is not excessively high.



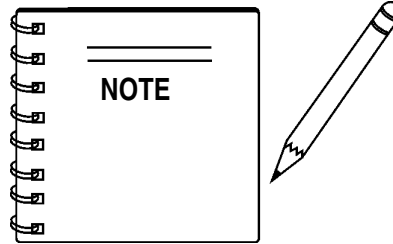

# EXPLANATION OF CODE IN REMARKS COLUMN

How to read the marks and remarks used in this parts book.

## Items Found In the “Remarks” Column

Serial Numbers-Where indicated, this indicates a serial number range (inclusive) where a particular part is used.

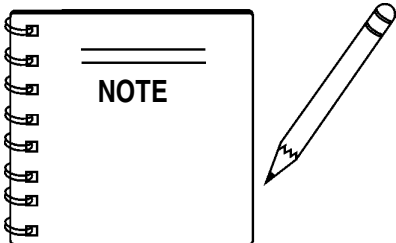
Model Number-Where indicated, this shows that the corresponding part is utilized only with this specific model number or model number variant.



If more than one of the same reference number is listed, the last one listed indicates newest (or latest) part available.

## Items Found In the “Items Number” Column

All parts with same symbol in the number column, \*, #, +, %, or <, belong to the same assembly or kit



The contents of this parts catalog are subject to change without notice.

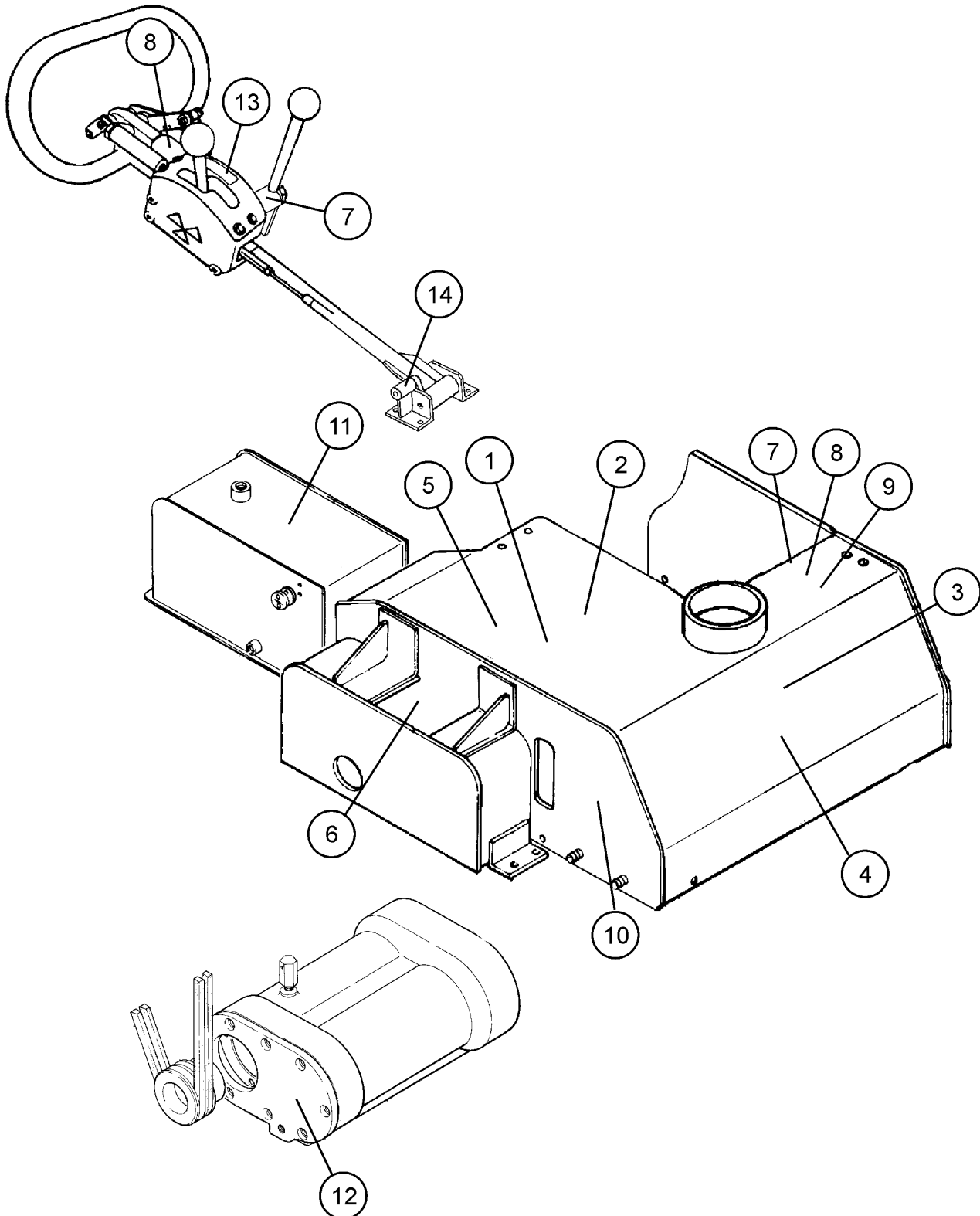
MQ MIKASA MDR-9GH VIBRATORY WALK-BEHIND  
ROLLER W/HONDA GX340QAE2 GASOLINE ENGINE

## *1 to 3 Units*

<u>Qty.</u>	<u>P/N</u>	<u>Description</u>
1 .....	0750800671 .....	CHAIN DRIVE
3 .....	501010440 .....	OIL FILTER, HYDRAULIC
6 .....	070100360 .....	V-BELT, A-36 VIBRATION
2 .....	502303040 .....	THROTTLE WIRE
6 .....	17210ZE3505 .....	ELEMENT AIR CLEANER
3 .....	35111880003 .....	KEY, IGNITION
6 .....	9807956846 .....	SPARK PLUG
1 .....	28462ZV7003 .....	STARTER ROPE

# MDR-9GH — DECAL PLACEMENT

## DECAL PLACEMENT



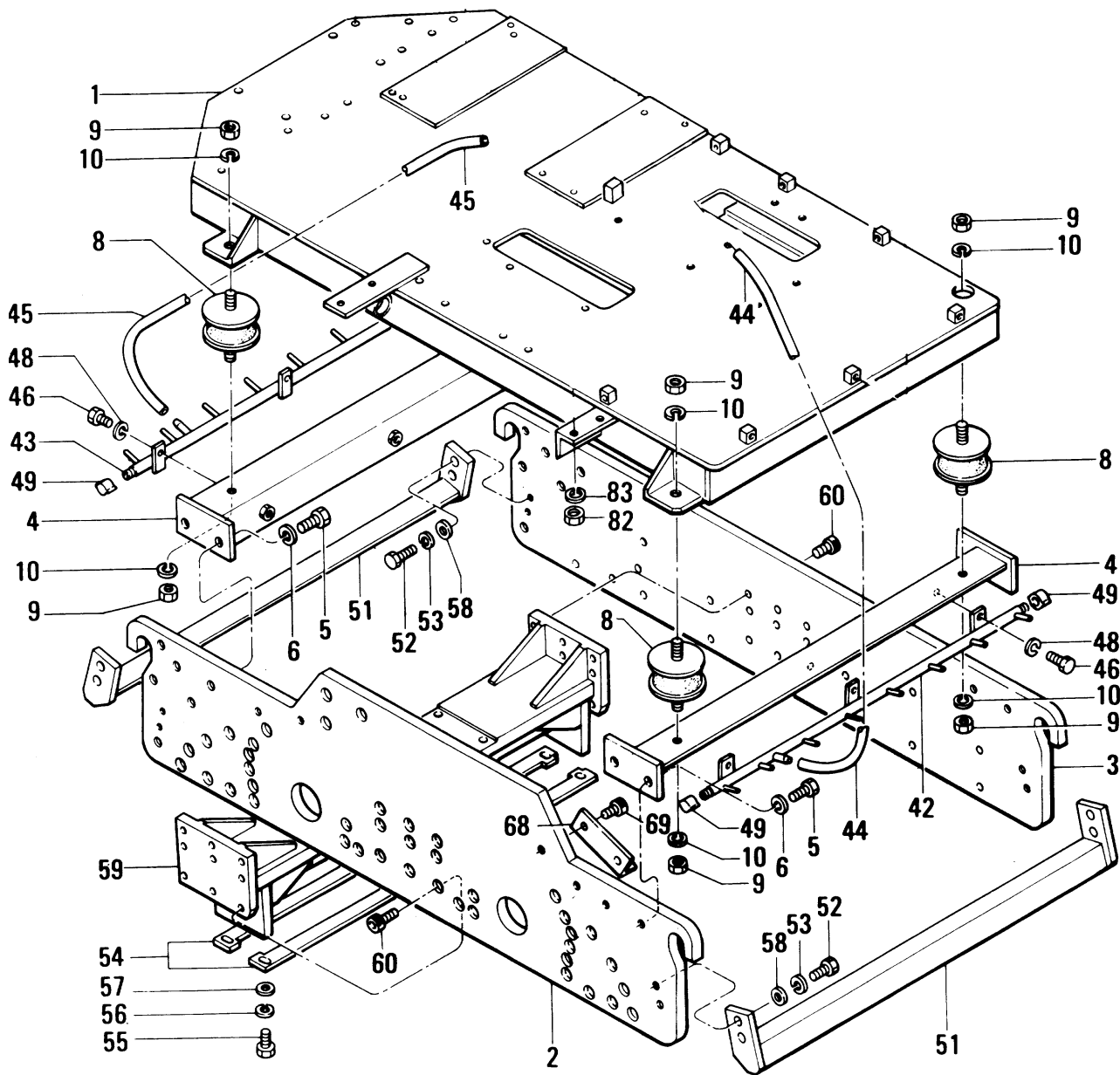
## MDR-9GH — DECAL PLACEMENT

### DECAL PLACEMENT

<u>NO.</u>	<u>PART NO.</u>	<u>PART NAME</u>	<u>QTY.</u>	<u>REMARKS</u>
1	920200591	PLATE, CAUTION	1	
2	920200630	PLATE, SERIAL NO.	1	
3	920201590	DECAL, MQ MARK 98X70	1	
4	920101510	DECAL, MIKASA MARK 440MM	1	
5	920203290	DECAL, CAUTION	1	
6	920200450	DECAL, OIL FILTER	1	
7	920101290	DECAL, VIBRATION	2	
8	920201100	DECAL, CLUTCH LEVER	2	
9	920200320	DECAL, WATER TANK	1	
10	920200440	DECAL, PROHIBIT TOW	1	
11	920200470	DECAL, OIL TANK	1	
12	920101480	DECAL, OIL LEVEL	1	
13	920101280	DECAL, FORWARD & REVERSE	1	
14	920101200	DECAL, GREASE	1	

# MDR-9GH — BODY ASSY.

BODY ASSY.

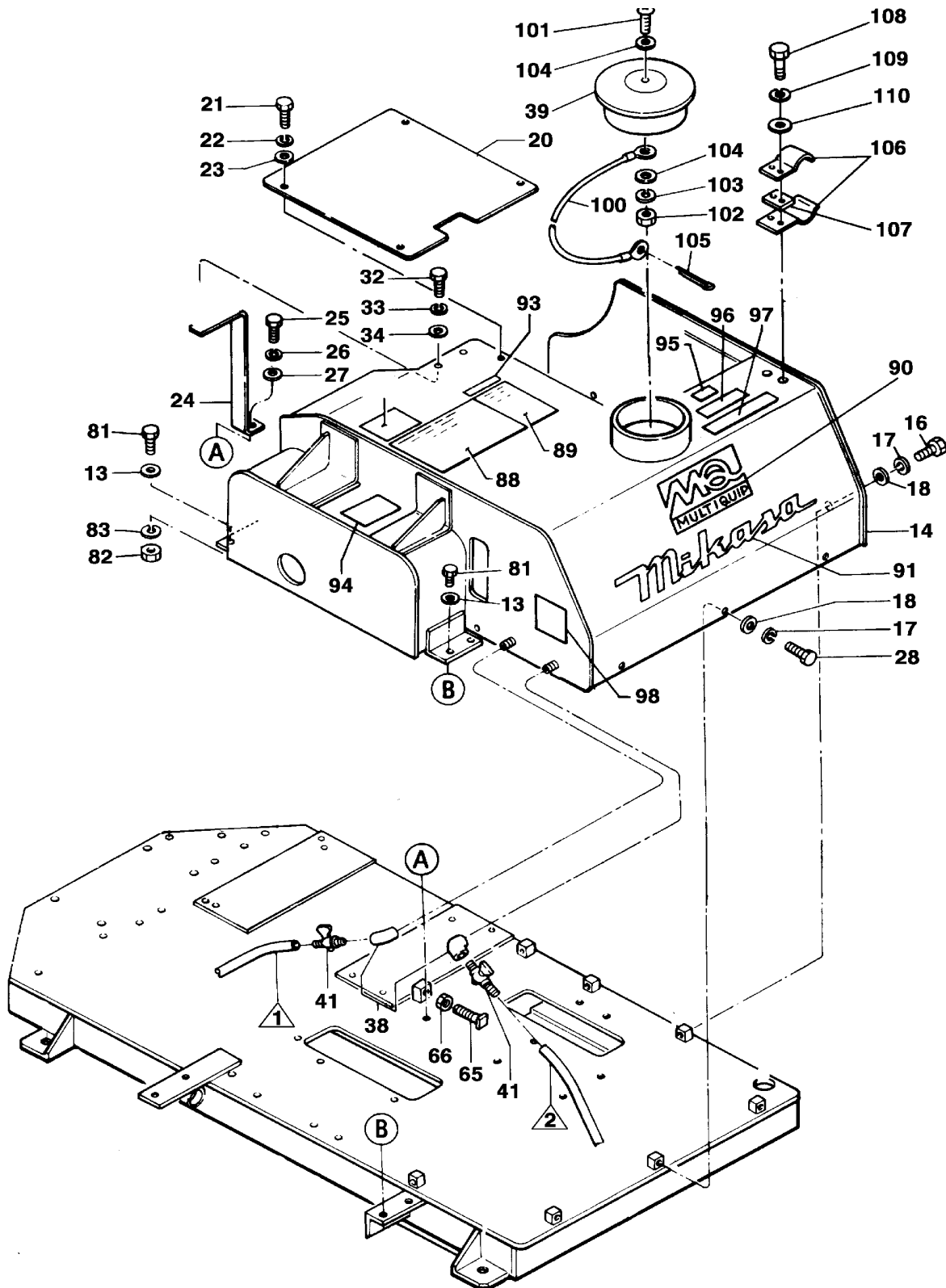


BODY ASSY.

<u>NO.</u>	<u>PART NO.</u>	<u>PART NAME</u>	<u>QTY.</u>	<u>REMARKS</u>
1	502101270	BASE	1	
2	502100720	SIDE PLATE, RIGHT	1	
3	502100710	SIDE PLATE, LEFT	1	
4	502200960	RUBBER PLATE	2	
5	001211430	BOLT 14X30 H	8	
6	030214350	LOCK WASHER M14	8	
8	930407021	SHOCK ABSORBER MED-70/MS	4	
9	020312100	NUT M12	8	
10	030212300	LOCK WASHER M12	8	
42	502201150	SPRINKLING PIPE, FRONT	1	
43	502201160	SPRINKLING PIPE, REAR	1	
44	502402930	VINYL PIPE 10X13X280	1	
45	502402940	VINYL PIPE 10X13X950	1	
46	001221025	BOLT 10X25 T	6	
48	030210250	LOCK WASHER M10	6	
49	501010150	CAP 1/4	4	
51	502302511	SCRAPER, END	2	
52	001221030	BOLT 10X30 T	8	
53	030210250	LOCK WASHER M10	8	
54	502424050	SCRAPER/CENTER	2	
55	001220825	BOLT 8X25 T	6	
56	030208200	LOCK WASHER M8	6	
57	952401560	WASHER 8.5X20X3	6	
58	031110160	FLAT WASHER M10	8	
59	502200990	BASE, SCRAPER	1	
60	001521225	SOCKET HEAD BOLT 12X25 T	18	
68	502403940	CHAIN COVER	2	
69	001521020	SOCKET HEAD BOLT 10X20 T	4	
82	020310080	NUT M10	4	
83	030210250	LOCK WASHER M10	4	

# MDR-9GH — FRONT COVER ASSY.

## FRONT COVER ASSY.





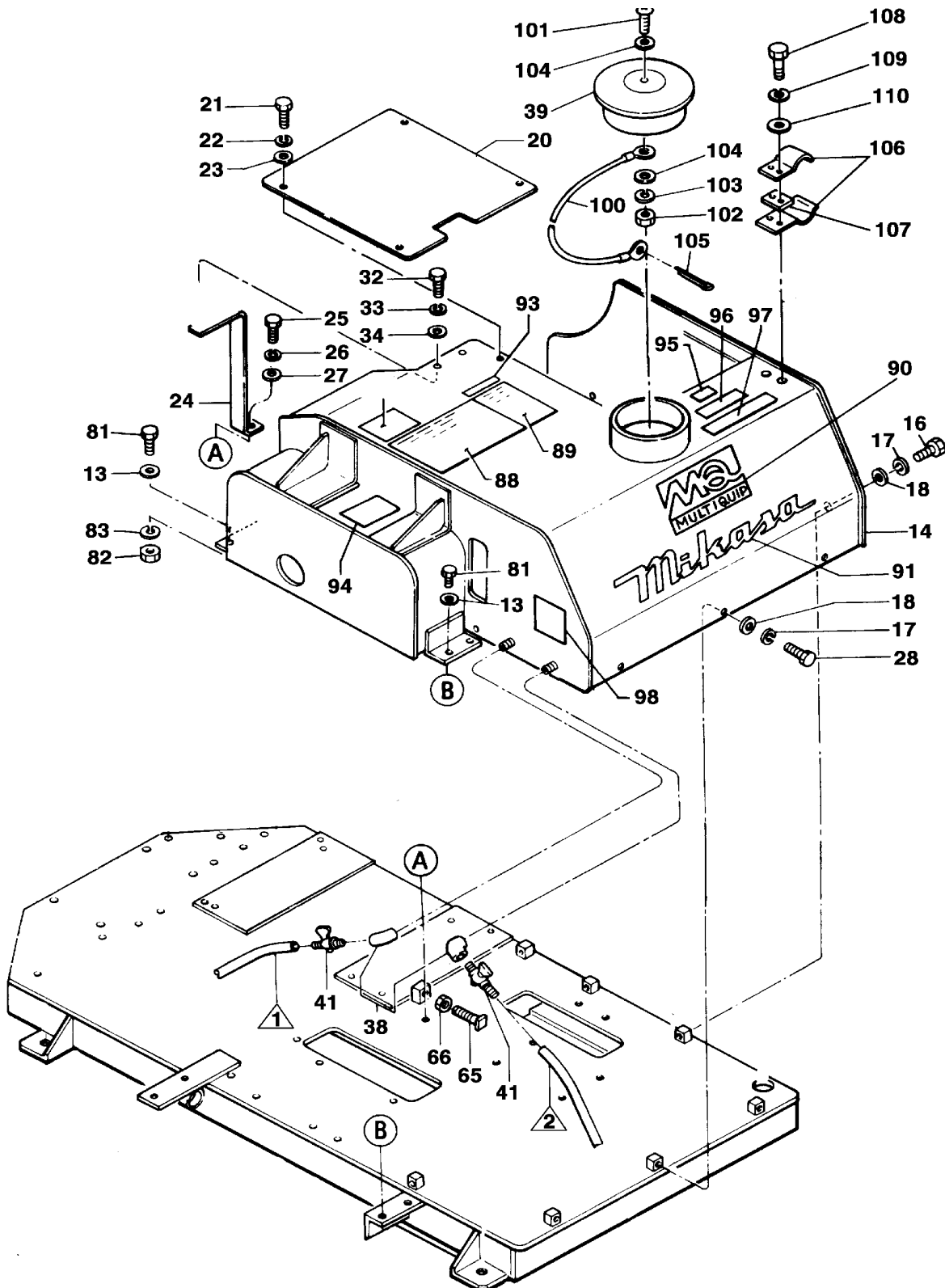
## MDR-9GH — FRONT COVER ASSY.

### FRONT COVER ASSY.

<u>NO.</u>	<u>PART NO.</u>	<u>PART NAME</u>	<u>QTY.</u>	<u>REMARKS</u>
13	031110160	FLAT WASHER M10	4	
14	502103800	FRONT COVER	1	
16	001220820	BOLT 8X20 T	4	
17	030208200	LOCK WASHER M8	7	
18	952401560	WASHER 8.5X20X3	7	
20	502302490	CHECK COVER	1	
21	001220815	BOLT 8X15 T	4	
22	030208200	LOCK WASHER M8	4	
23	031108160	FLAT WASHER M8	4	
24	502302500	SUPPORT/COVER	1	
25	001221020	BOLT 10X20 T	1	
26	030210250	LOCK WASHER M10	1	
27	021110160	FLAT WASHER M10	1	
28	001220825	BOLT 8X25 T	3	
31	502215470	BELT COVER	1	
32	001221020	BOLT 10X20 T	2	
33	030210250	LOCK WASHER M10	2	
34	031110160	FLAT WASHER M10	2	
35	001221015	BOLT 10X15 T	2	
36	030210250	LOCK WASHER M10	2	
37	031110160	FLAT WASHER M10	2	
38	502010650	ELBOW 90 DEG. 1/4	2	
39	407310670	TANK CAP D108-120, RUBBER	1	

# MDR-9GH — FRONT COVER ASSY. (CONTINUED)

FRONT COVER ASSY.



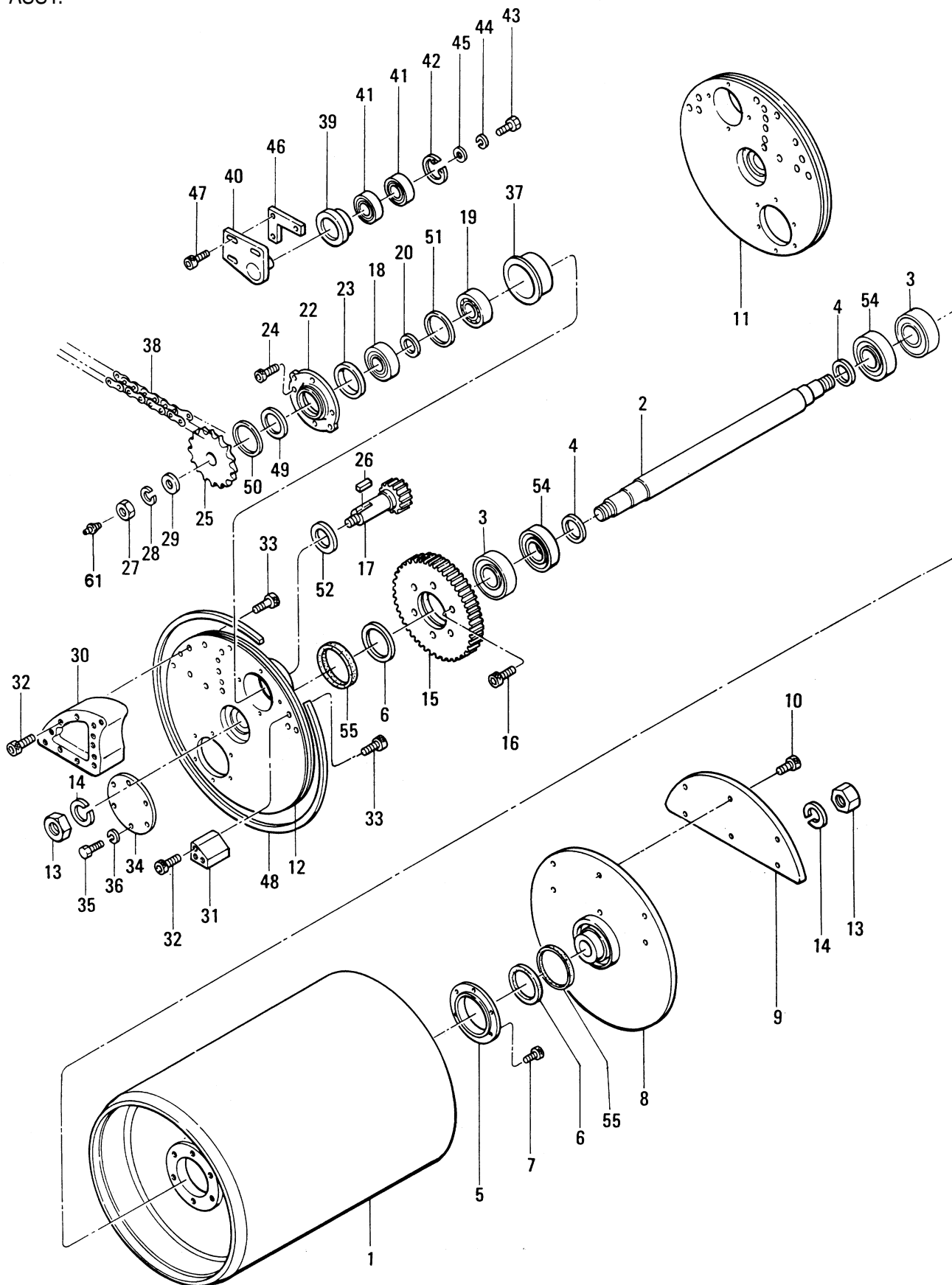
## MDR-9GH — FRONT COVER ASSY. (CONTINUED)

### FRONT COVER ASSY.

<u>NO.</u>	<u>PART NO.</u>	<u>PART NAME</u>	<u>QTY.</u>	<u>REMARKS</u>
41	954403241	COCK PT 1/4, BH-1211 (AL)	2	
65	001801050	BOLT 10X50 WHOLE THREAD	1	
66	020310080	NUT M10		
81	001211030	BOLT 10X30 H	4	
82	020310080	NUT M10	4	
83	030210250	LOCK WASHER M10	4	
88	920200591	PLATE, CAUTION	1	
89	920200630	PLATE, SERIAL NO.	1	
90	920201590	DECAL, MQ MARK 98X70	1	
91	920101510	DECAL, MIKASA MARK 440MM	1	
92	920203290	DECAL, CAUTION	1	
93	920206450	PLATE, MADE IN JAPAN	1	
94	920200450	DECAL, OIL FILTER	1	
95	920101290	DECAL, VIBRATION	1	
96	920201100	DECAL, (CLUTCH LEVER)	1	
97	920200320	DECAL, WATER TANK	1	
98	920200440	DECAL, PROHIBIT TOW	1	
100	959402990	ROPE	1	
101	091005020	SCREW 5X20	1	
102	020305040	NUT M5	1	
103	030205130	LOCK WASHER M5	1	
104	031105080	FLAT WASHER M5	2	
105	025203020	SPLIT COTTER PIN 3X20	1	
106	959403251	PLATE SPRING	2	
107	502420150	SPACER	1	
108	001200820	BOLT 8X20	2	
109	030208200	LOCK WASHER M8	2	
110	031108160	FLAT WASHER M8	2	

# MDR-9GH — AXLE ASSY.

AXLE ASSY.

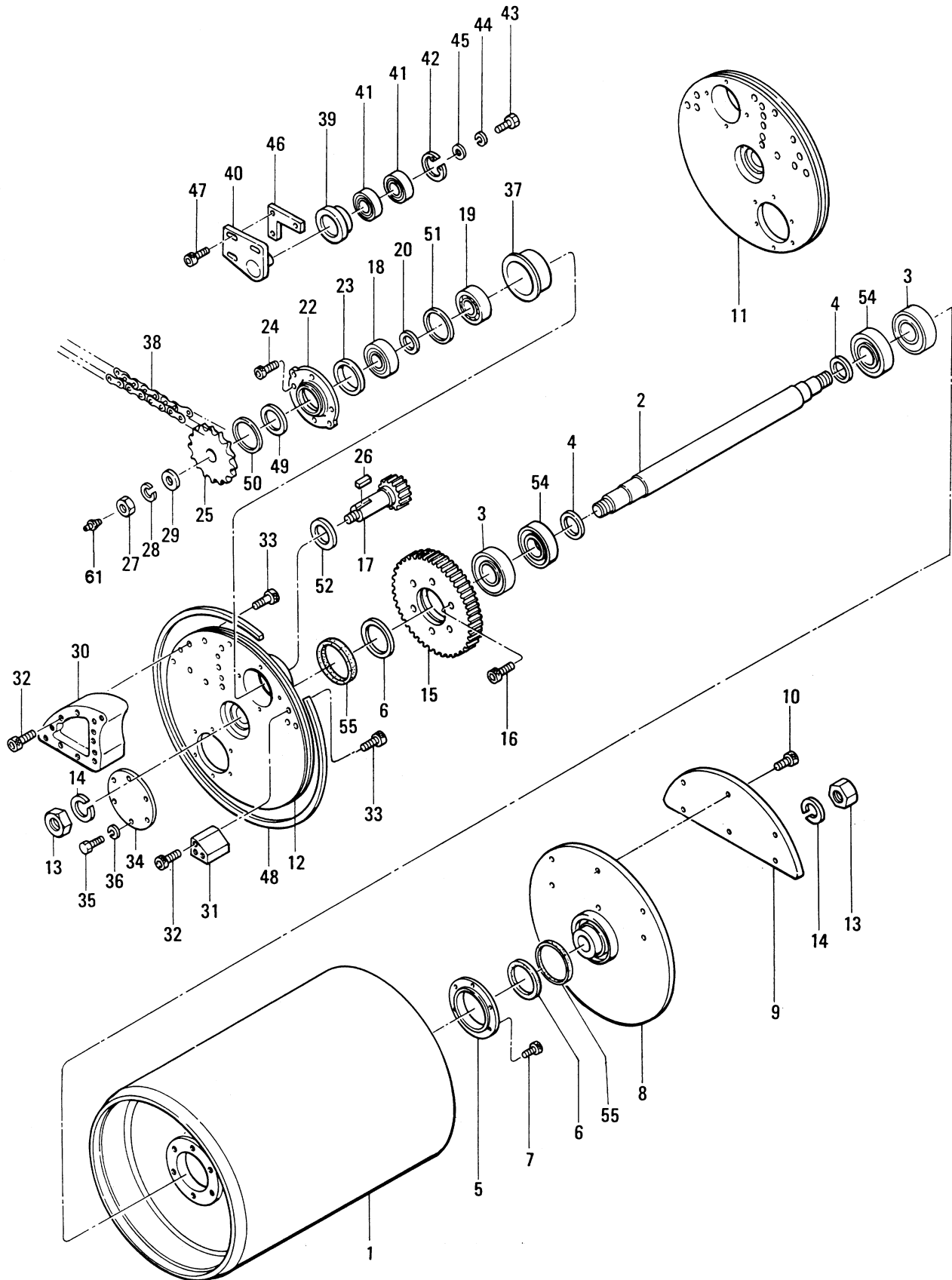


## AXLE ASSY.

<u>NO.</u>	<u>PART NO.</u>	<u>PART NAME</u>	<u>QTY.</u>	<u>REMARKS</u>
1	502101570	DRUM	2	
2	502202290	ROLLER SHAFT	2	
3	044006309	BEARING 6309VV	4	
4	952400940	SPACER 45605	4	
5	502302420	BEARING COVER	2	
6	060406010	OIL SEAL TC-689012	4	
7	001521025	SOCKET HEAD BOLT 10X25 T	12	
8	502200930	BRACKET/L	2	
9	502302430	SPACER	2	
10	001521240	SOCKET HEAD BOLT 12X40 T	12	
11	502200940	BRACKET/R FRONT	1	
12	502200950	BRACKET/R REAR	1	
13	020130240	NUT M30, P2.0	4	
14	030230750	LOCK WASHER M30	4	
15	502302440	GEAR 57	2	
16	001521040	SOCKET HEAD BOLT 10X40 T	12	
17	502303370	GEAR SHAFT	2	
17	502338050	GEAR SHAFT	2	
18	044006370	BEARING 6307VV	2	
19	047910050	ROLLER BEARING NF307W	2	
20	952401240	SPACER 35453	2	
20	952406190	SPACER 35X45X3 S	2	
22	502302460	COVER/GEAR SHAFT	2	
23	060305010	OIL SEAL TB-55729	2	
24	001520820	SOCKET HEAD BOLT 8X20 T	8	
25	502402720	SPROCKET 15	2	
26	951400090	KEY 10X8X33	2	
27	020118150	NUT M18, P1.5	2	
28	030218460	LOCK WASHER M18	2	
29	952400950	WASHER 19456	2	
30	502305360	BLOCK	2	
31	502303590	CYLINDER BLOCK	2	
32	001521235	SOCKET HEAD BOLT 12X35 T	30	
33	001521240	SOCKET HEAD BOLT 12X40 T	30	
34	502402740	BRACKET COVER	2	
35	001210820	BOLT 8X20 H	12	
36	030208200	LOCK WASHER M8	12	
37	502403090	BEARING HOLDER	2	
38	075080061	CHAIN RS80-61	1	
39	502402920	TIGHTENER	1	

# MDR-9GH — AXLE ASSY. (CONTINUED)

## AXLE ASSY.



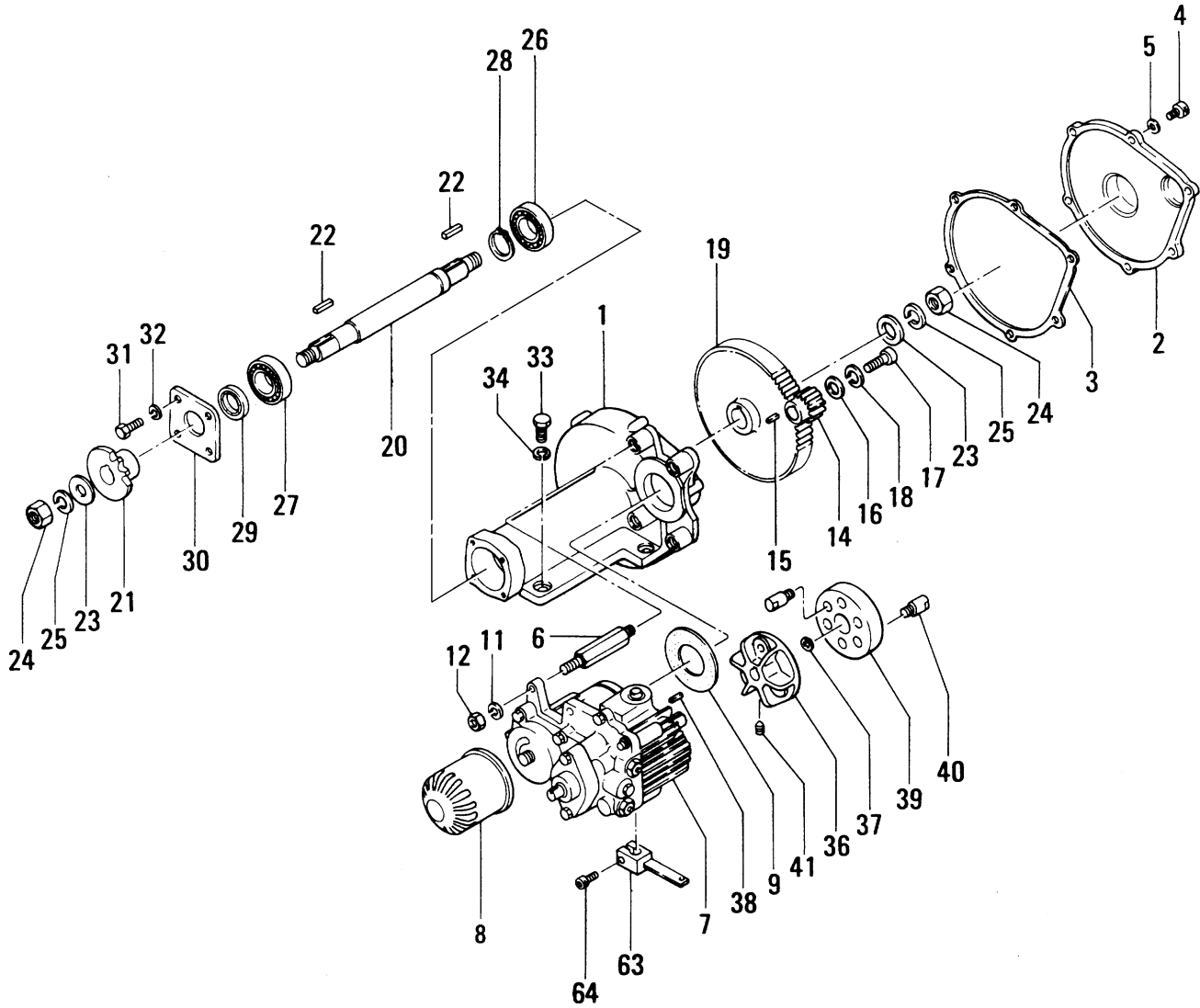
## MDR-9GH — AXLE ASSY. (CONTINUED)

### AXLE ASSY.

<u>NO.</u>	<u>PART NO.</u>	<u>PART NAME</u>	<u>QTY.</u>	<u>REMARKS</u>
40	502302480	TIGHTENER PLATE (SHAFT)	1	
41	044006205	BEARING 6205VV	2	
42	080100520	STOP RING R-52	1	
43	001210820	BOLT 8X20 H	1	
44	030208200	LOCK WASHER M8	1	
45	952400130	WASHER 9304	1	
46	502402750	TIGHTENER PLATE HOLDER	1	
47	001521230	SOCKET HEAD BOLT 12X30 T	3	
48	502402760	FELT SEAL 6X8X1350	2	
49	502402770	FELT SEAL 6X8X188	2	
50	502402780	FELT SEAL 5X6X217	2	
51	952401330	COLLAR 72803	2	
52	060604030	OIL SEAL VC-45686	2	
54	042006309	BEARING 6309ZZ	4	
55	502408150	FELT RING 901027/BRACKET	4	
61	351010050	GREASE FITTING A-MT6X1	2	

# MDR-9GH — TRANSMISSION ASSY.

TRANSMISSION ASSY.





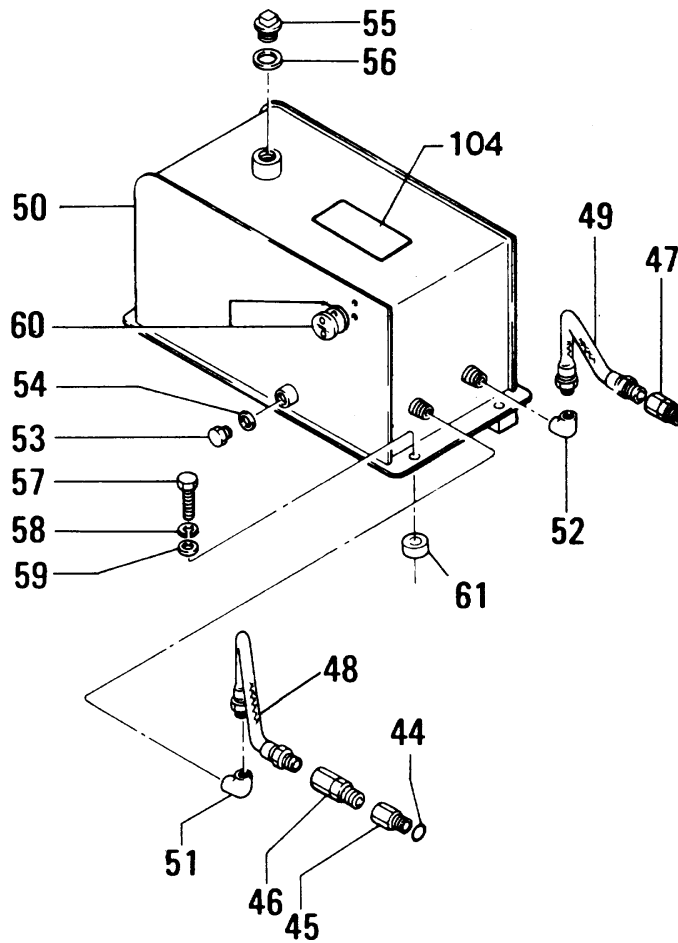
# MDR-9GH — TRANSMISSION ASSY.

## TRANSMISSION ASSY.

<u>NO.</u>	<u>PART NO.</u>	<u>PART NAME</u>	<u>QTY.</u>	<u>REMARKS</u>
1	502010530	GEAR CASE	1	
2	502010540	COVER, GEAR CASE	1	
3	501010410	PACKING, GEAR CASE COVER	1	
4	001520620	SOCKET HEAD BOLT 6X20 T	6	
5	031106100	FLAT WASHER M6	6	
6	501010420	SET BOLT, 87L-M12-M10	4	
7	501010430	TRANSMISSION 1515-522	1	
8	501010440	OIL FILTER	1	
9	501010450	PACKING/TRANSMISSION	1	
11	030210250	LOCK WASHER M10	4	
12	020310080	NUT M10	4	
14	501010460	PINION 15	1	
15	951400100	KEY 5X5X35	1	
16	952400130	WASHER 9304	1	
17	001210820	BOLT 8X20 H	1	
18	030208200	LOCK WASHER M8	1	
19	502303350	GEAR 80	1	
20	502010570	DRIVE SHAFT	1	
21	501010500	SPROKET 9	1	
22	951400110	KEY 7X7X35	2	
23	952400170	WASHER 19454	2	
24	020118150	NUT M18, P1.5	2	
25	030218460	LOCK WASHER M18	2	
26	042006207	BEARING 6207ZZ	1	
27	042006306	BEARING 6306ZZ	1	
28	080200350	STOP RING S-35	1	
29	060303030	OIL SEAL TB-30428	1	
30	501010520	BEARING COVER	1	
31	001220825	BOLT 8X25 T	4	
32	030208200	LOCK WASHER M8	4	
33	001211025	BOLT 10X25 H	4	
34	030210250	LOCK WASHER M10	4	
36	502302530	FLANGE FAN	1	
37	080100160	STOP RING R-16	1	
38	502010590	KEY 5X5X22/4DK	1	
39	502321570	RUBBER COUPLING	1	
40	515447020	COUPLING PIN	6	
41	099208012	SOCKET HEAD SCREW 8X12 T	2	
63	502402800	LEVER	1	
64	001521025	SOCKET HEAD BOLT 10X25 T	1	

# MDR-9GH — HYDRAULIC OIL TANK ASSY.

HYDRAULIC OIL TANK ASSY.



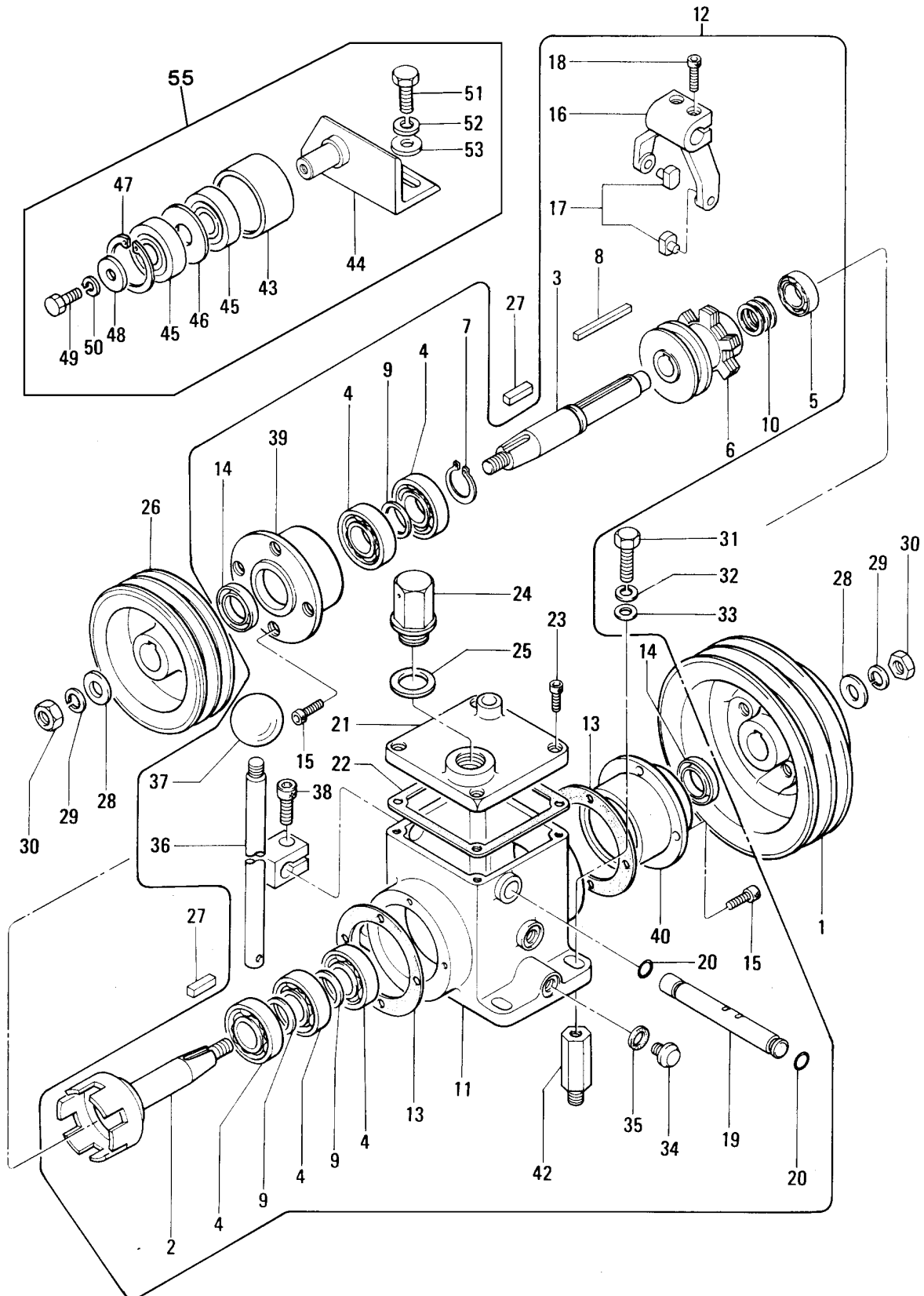
## MDR-9GH — HYDRAULIC OIL TANK ASSY.

### HYDRAULIC OIL TANK ASSY.

<u>NO.</u>	<u>PART NO.</u>	<u>PART NAME</u>	<u>QTY.</u>	<u>REMARKS</u>
44	050200160	O-RING P-16	1	
45	501010720	JOINT 3/4-16	1	
46	501010590	JOINT 3/8	1	
47	501010600	JOINT 1/4	1	
48	502302850	OIL HOSE 3/8 320L	1	
49	502302840	OIL HOSE 1/4 320L	1	
50	502201000	OIL TANK	1	
51	502010640	ELBOW 90 DEG. 3/8	1	
52	502010650	ELBOW 90 DEG. 1/4	1	
53	953405270	PLUG 1/4X14 13L	1	
54	953405260	PACKING 1/4 (CU)	1	
55	953405840	DRAIN PLUG M18 (H)	1	
56	953400020	PACKING 19302	1	
57	001221035	BOLT 10X35 T	4	
58	030210250	LOCK WASHER M10	4	
59	031110160	FLAT WASHER M10	4	
60	959010110	LEVEL GAUGE/SP-1 W/P	1	
61	952401960	COLLAR 11X30X16	1	
104	920200470	DECAL, OIL TANK	1	

# MDR-9GH — CLUTCH BOX ASSY.

CLUTCH BOX ASSY.



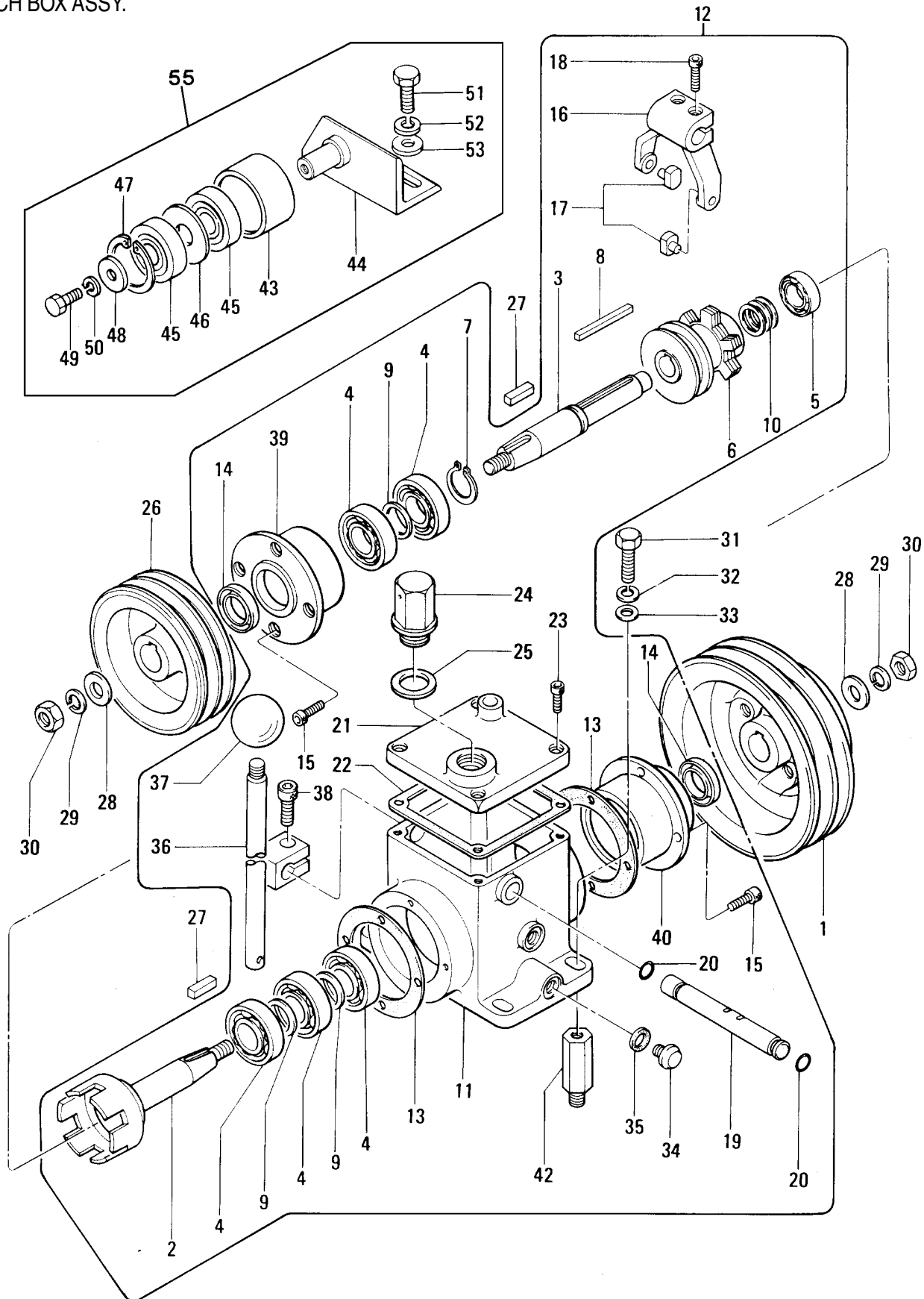
# MDR-9GH — CLUTCH BOX ASSY.

## CLUTCH BOX ASSY.

<u>NO.</u>	<u>PART NO.</u>	<u>PART NAME</u>	<u>QTY.</u>	<u>REMARKS</u>
1	502302610	CLUTCH PULLEY/IN	1	
2*	502302620	CLUTCH SHAFT/IN	1	
3*	502302630	CLUTCH SHAFT/OUT	1	
4*	040006205	BEARING 6205	5	
5*	040006202	BEARING 6202	1	
6*	501010800	CLUTCH SL1.2-20/OS225	1	
7*	080200250	STOP RING S-25	1	
8*	951400060	KEY 5X5X58	1	
9*	501010810	COLLAR 25322/BEARING	3	
10*	501010822	SPACER 0.8T/CLUTCH	AR	
10*	501010823	SPACER 1.0T/CLUTCH	AR	
10*	501010824	SPACER 2.3T/CLUTCH	AR	
10*	501010825	SPACER 3.2T/CLUTCH	AR	
11*	501010830	CLUTCH CASE	1	
12	502910010	CLUTCH BOX ASSY. ....	1	..... INCLUDES ITEMS W/*
13*	501010830	PACKING/BEARING HOLDER	2	
14*	060102010	OIL SEAL SB-25388	2	
15*	001520620	SOCKET HEAD BOLT 6X20 T	8	
16*	501010850	SHIFTER FORK	1	
17*	501010860	FORK BLOCK	2	
18*	001520625	SOCKET HEAD BOLT 6X25 T	2	
19*	501010870	SHIFTER SHAFT	1	
20*	050200110	O-RING P-11	2	
21*	501301160	COVER, CLUTCH CASE	1	
22*	501010890	PACKING, CLUTCH CASE	1	
23*	001520625	SOCKET HEAD BOLT 6X25 T	4	
24*	501010900	PLUG 3/4	1	
25*	501010910	PACKING 3/4	1	
26	502302640	CLUTCH PULLEY/OUT	1	
27	951400070	KEY 7X7X26	2	
28	952400140	WASHER 13304	2	
29	030212300	LOCK WASHER M12	2	
30	020312100	NUT M12	2	
31	001221035	BOLT 10X35 T	4	
32	030210250	LOCK WASHER M10	4	
33	952401860	WASHER 112545	4	
34*	953400270	PLUG 1/4X14 10L	2	
34*	953405270	PLUG 1/4X14 13L	2	

# MDR-9GH — CLUTCH BOX ASSY. (CONTINUED)

CLUTCH BOX ASSY.



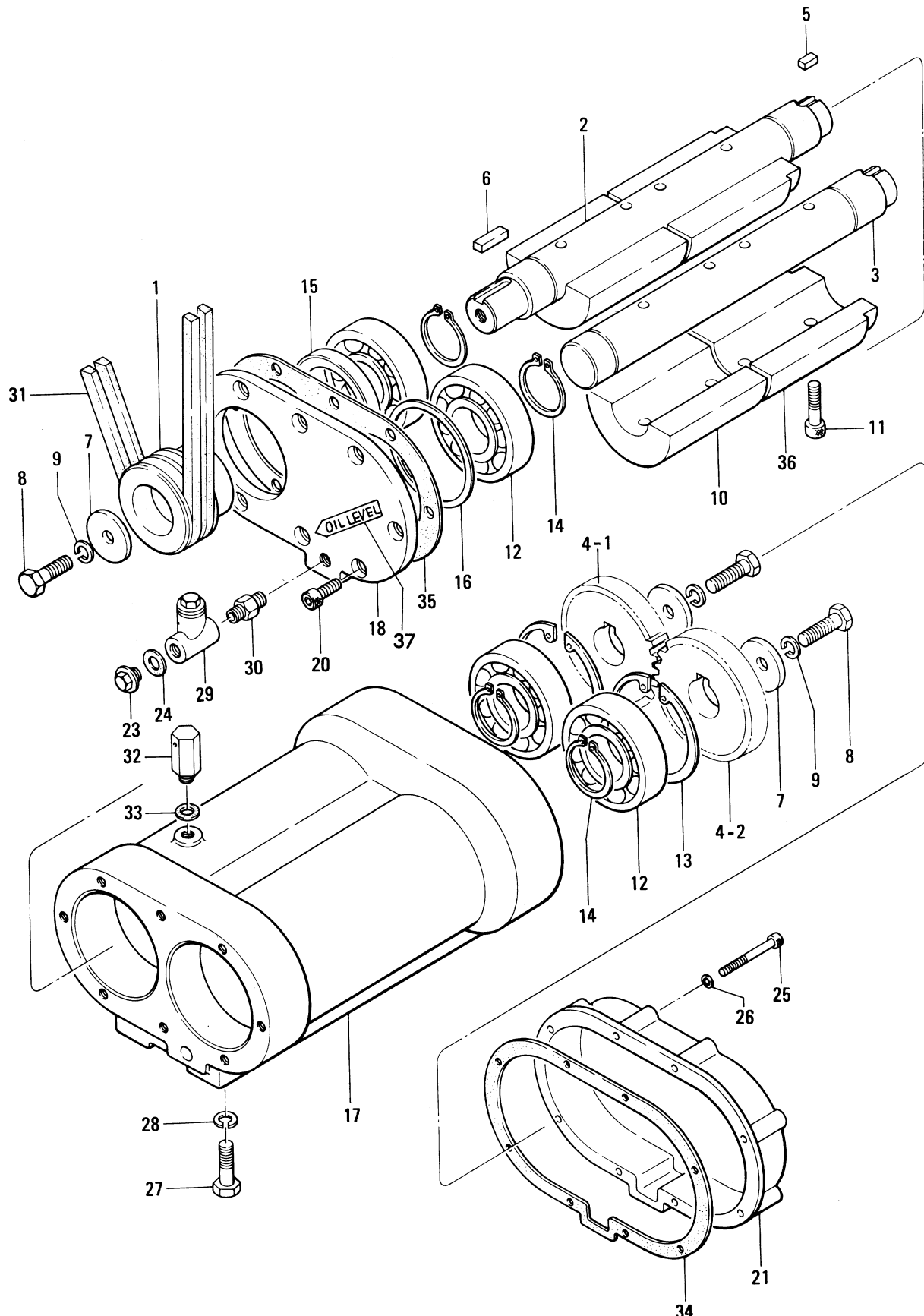
# MDR-9GH — CLUTCH BOX ASSY. (CONTINUED)

CLUTCH BOX ASSY.

<u>NO.</u>	<u>PART NO.</u>	<u>PART NAME</u>	<u>QTY.</u>	<u>REMARKS</u>
35*	953405260	PACKING 1/4 (CU)	2	
36*	502302650	CLUTCH LEVER	1	
37*	959402980	BALL GRIP 40D-M12	1	
38*	001521025	SOCKET HEAD BOLT 10X25 T	1	
39*	501010950	BEARING HOLDER	1	
40*	502302660	BEARING HOLDER/INPUT SIDE	1	
42*	501402260	SET BOLT, L50M10M12/CLUTCH	4	
43#	501402400	TIGHTENER PULLEY	1	
44#	501302160	TIGHTENER SUPPORT	1	
45#	042006204	BEARING 6204ZZ	2	
46#	952400930	COLLAR 20252	1	
47#	080100470	STOP RING R-47	1	
48#	952400130	WASHER 9304	1	
49#	001200820	BOLT 8X20	1	
50#	030208200	LOCK WASHER M8	1	
51#	001221035	BOLT 10X35 T	2	
52#	030210250	WASHER, LOCK M10	2	
53#	031110160	WASHER, FLAT M10	2	
55	501910040	BELT TIGHTENER ASSY. ....	1	..... INCLUDES ITEMS W/#

# MDR-9GH — VIBRATION CASE ASSY.

VIBRATION CASE ASSY.





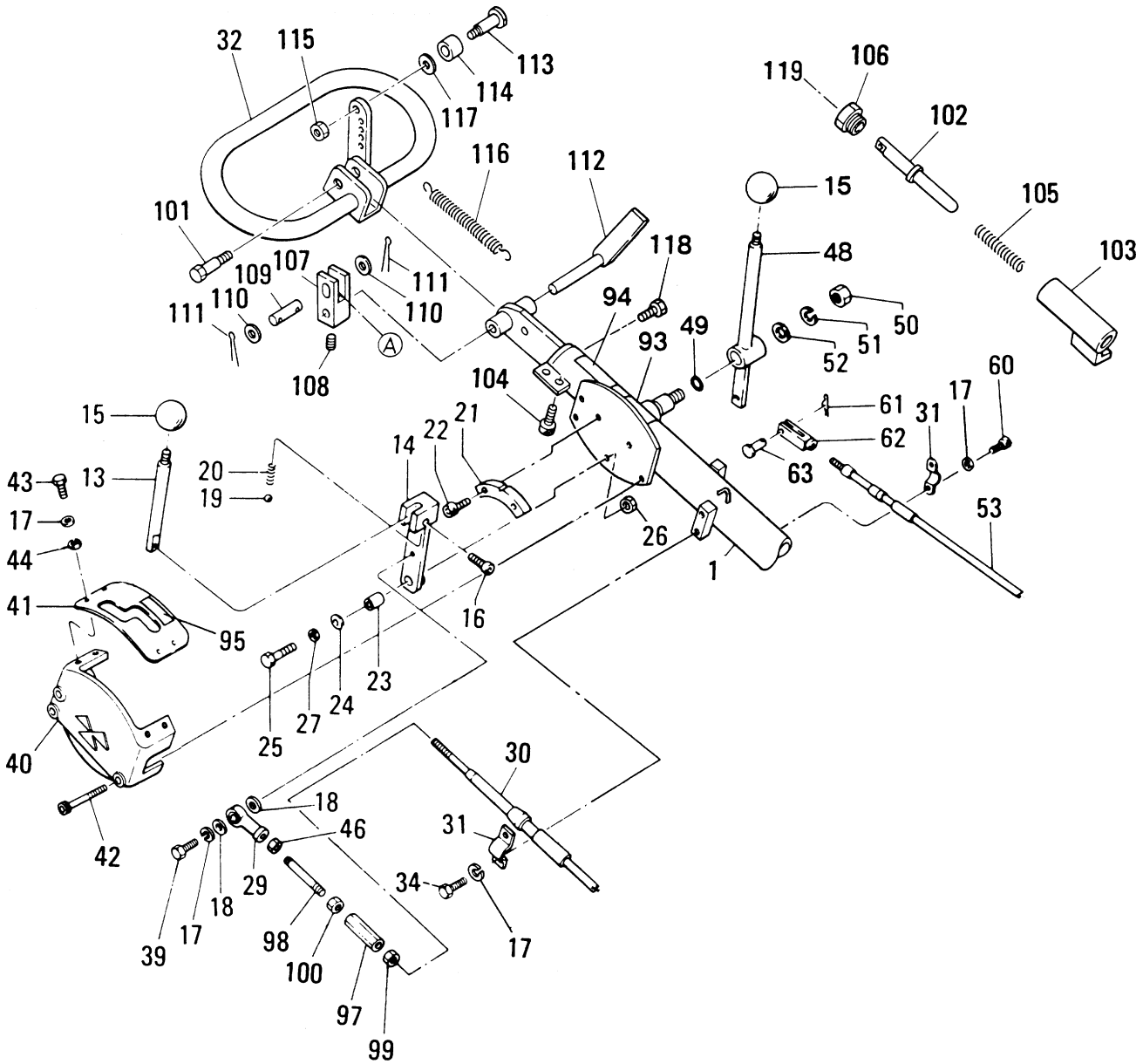
# MDR-9GH — VIBRATION CASE ASSY.

## VIBRATION CASE ASSY.

<u>NO.</u>	<u>PART NO.</u>	<u>PART NAME</u>	<u>QTY.</u>	<u>REMARKS</u>
1	502302570	VIBRATING PULLEY	1	
2	502201010	ROTARY SHAFT/L	1	
3	502201020	ROTARY SHAFT/R	1	
4-1	502302582	GEAR (DRIVE-1P)	1	
4-2	502302581	GEAR 44 (DRIVEN-2P)	1	
5	951400081	KEY 10X8X17	2	
6	951400090	KEY 10X8X33	1	
7	952400900	WASHER 13446	3	
8	001211235	BOLT 12X35 H	3	
9	030212300	LOCK WASHER M12	3	
10	502302590	ECCENTRIC ROTATOR	2	
11	001521040	SOCKET HEAD BOLT 10X40 T	8	
12	040006309	BEARING 6309	4	
13	080101000	STOP RING R-100	2	
14	080200450	STOP RING S-45	4	
15	060106010	OIL SEAL SB-659013	1	
15	060206020	OIL SEAL SC-659013	1	
16	952400911	SPACER 801003	1	
17	502100650	VIBRATING CASE	1	
18	502302600	CASE COVER	1	
20	001521025	SOCKET HEAD BOLT 10X25 T	8	
21	502201030	GEAR COVER	1	
23	953400270	PLUG 1/4X14 10L	2	
23	953405270	PLUG 1/4X14 13L	2	
24	953405260	PACKING 1/4 (CU)	2	
25	001520652	SOCKET HEAD BOLT 6X60 T	8	
26	031106100	FLAT WASHER M6	8	
27	001221445	BOLT 14X45 T	14	
28	030214350	LOCK WASHER M14	14	
29	502403140	T-JOINT	1	
30	502010860	NIPPLE PT1/4	1	
31	070100360	V-BELT A-36	2	
32	502402300	BREATHER	1	
33	953405260	PACKING 1/4 (CU)	1	
34	502303010	PACKING, VIBRATION CASE/A	1	
35	502303020	PACKING, VIBRATION CASE/B	1	
36	502305480	ECCENTRIC ROTATOR	2	
37	920101480	DECAL, OIL LEVEL	1	

# MDR-9GH — UPPER CONTROL HANDLE ASSY.

## UPPER CONTROL HANDLE ASSY.



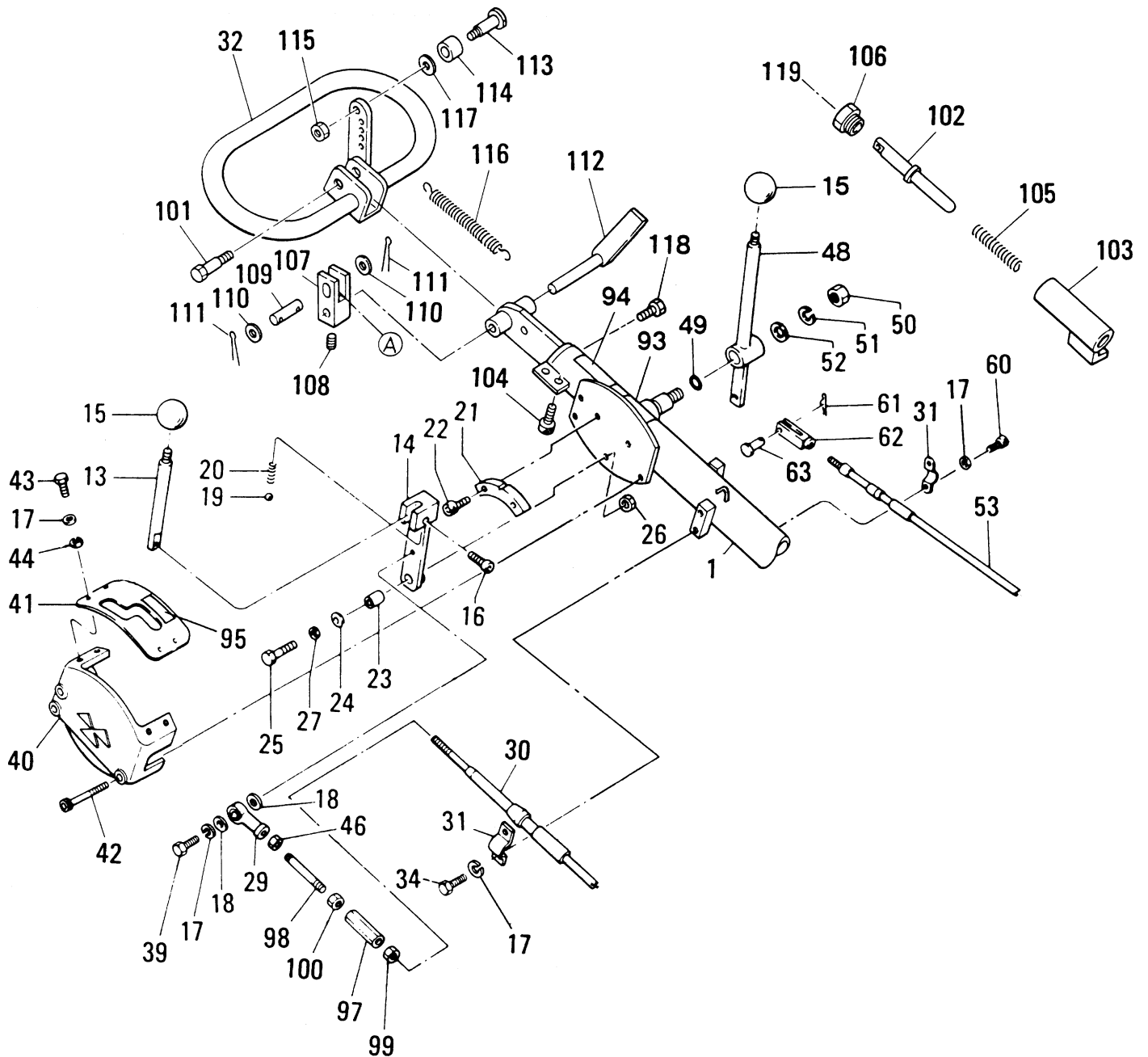
## MDR-9GH — UPPER CONTROL HANDLE ASSY.

### UPPER CONTROL HANDLE ASSY.

<u>NO.</u>	<u>PART NO.</u>	<u>PART NAME</u>	<u>QTY.</u>	<u>REMARKS</u>
1	502101480	BAR HANDLE, D.C.	1	
13	501011090	TRAVELING LEVER	1	
14	501011100	LINK	1	
15	959402980	BALL GRIP 40D-M12	2	
16	001520620	SOCKET HEAD BOLT 6X20 T	1	
17	030206150	LOCK WASHER M6	15	
18	031106100	FLAT WASHER M6	6	
19	501011110	STEEL BALL	1	
20	501011120	SPRING, 1.2X8X34	1	
21	505422750	GUIDE	1	
22	001520615	SOCKET HEAD BOLT 6X15 T	2	
23	501011140	BUSH 8918, LINK	1	
24	501011150	CONICAL SPRING WASHER	1	
25	001200835	BOLT 8X35	1	
26	020308060	NUT M8	1	
27	031108160	FLAT WASHER M8	1	
29	501011162	ROD END PR6-209	3	
30	502314420	CABLE ASSY./C2110	1	
31	501011180	CLAMP HC-40	4	
32	501203980	HANDLE, D.C.	1	
34	001210615	BOLT 6X15 H	4	
39	001210620	BOLT 6X20 H	2	
40	501202200	LEVER COVER, D.C.	1	
41	501011220	LEVER GUIDE	1	
42	001520652	SOCKET HEAD BOLT 6X60 T	3	
43	001210615	BOLT 6X15 H	4	
44	031106100	FLAT WASHER M6	4	
48	501011310	VIBRATING LEVER	1	
49	050200160	O-RING P-16	1	
50	020312100	NUT M12	1	
51	030212300	LOCK WASHER M12	1	
52	031112230	FLAT WASHER M12	1	
53	502314410	CABLE ASSY./C2550	1	
60	001220615	BOLT 6X25 T	4	

# MDR-9GH — UPPER CONTROL HANDLE ASSY. (CONTINUED)

UPPER CONTROL HANDLE ASSY.



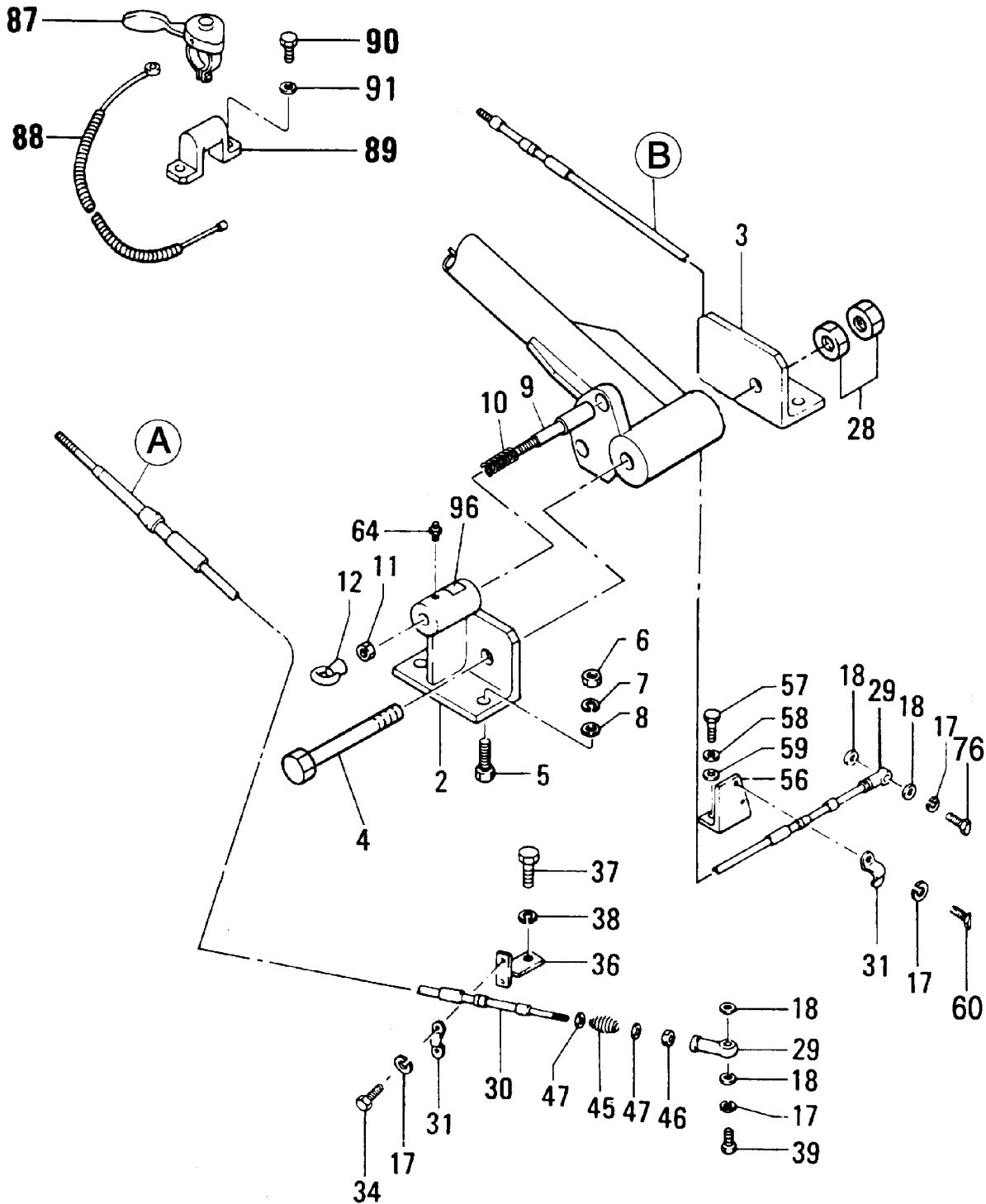
# MDR-9GH — UPPER CONTROL HANDLE ASSY. (CONTINUED)

## UPPER CONTROL HANDLE ASSY.

<u>NO.</u>	<u>PART NO.</u>	<u>PART NAME</u>	<u>QTY.</u>	<u>REMARKS</u>
61	025202020	SPLIT COTTER PIN 2X20	1	
62	502010930	CLEVIS	1	
63	502010940	CLEVIS PIN	1	
93	920101290	DECAL, VIBRATION	1	
94	920201100	DECAL, CLUTCH LEVER	1	
95	920101280	DECAL / FORWARD & REVERSE	1	
97	501413650	TURN BUCKLE	1	
98	501413660	ADJUST BOLT	1	
99	020306050	NUT M6	1	
100	022910090	NUT M6 (L)	1	
101	501407790	HANDLE PIN, D.C.	1	
102	501305190	ROD, D.C.	1	
103	502416960	ROD-GUIDE	1	
104	001520815	SOCKET HEAD BOLT 8X15 T	2	
105	501407810	ROD SPRING, D.C.	1	
106	501407820	NUT, D.C.	1	
107	501416950	LINK, D.C.	1	
108	099206008	SOCKET HEAD SCREW 6X8 T	1	
109	501407840	LINK PIN, D.C., 6X28-23	1	
110	031106100	FLAT WASHER M6	2	
111	025202012	SPLIT COTTER PIN 2X12	2	
112	501416970	LEVER, D.C.	1	
113	001200830	BOLT 8X30	1	
114	501407880	GUIDE ROLLER, D.C.	1	
115	020308060	NUT M8	1	
116	501407890	LEVER SPRING, D.C.	1	
117	031108160	FLAT WASHER M8	1	
118	001220815	BOLT 8X15 T	1	
119	502910020	HANDLE STOPPER	1	

# MDR-9GH — LOWER CONTROL HANDLE ASSY.

LOWER CONTROL HANDLE ASSY.



## NOTES:

- (A) UPPER CONTROL ARM ASSY., ITEM 30
- (B) UPPER CONTROL ARM ASSY., ITEM 53

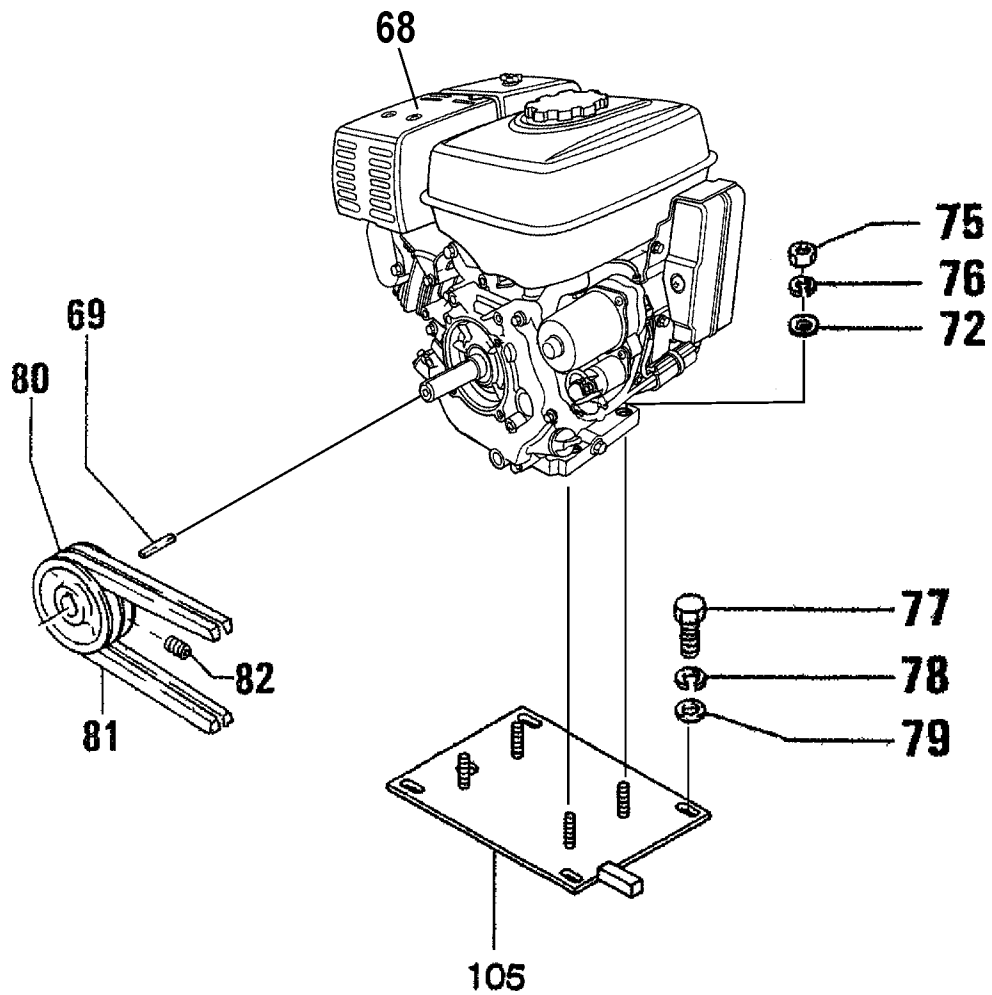
## MDR-9GH — LOWER CONTROL HANDLE ASSY.

### LOWER CONTROL HANDLE ASSY.

<u>NO.</u>	<u>PART NO.</u>	<u>PART NAME</u>	<u>QTY.</u>	<u>REMARKS</u>
2	501302670	HANDLE BRACKET, RIGHT	1	
3	501302680	HANDLE BRACKET, LEFT	1	
4	501402860	BOLT 20X170	1	
5	001221245	BOLT 12X45 T	4	
6	020312100	NUT M12	4	
7	030212300	LOCK WASHER M12	4	
8	031112230	FLAT WASHER M12	4	
9	501402870	HANDLE STOPPER	1	
10	501402880	SPRING/HANDLE (1.4X18X44)	1	
11	020310080	NUT M10	1	
12	959010413	EYE NUT M10	1	
28	020120160	NUT M20, P1.5	2	
29	501011162	ROD END PR6-209	3	
30	502314420	CABLE ASSY./C2110	1	
31	501011180	CLAMP HC-40	4	
34	001210615	BOLT 6X15 H	4	
36	502402900	CABLE STOPPER	1	
37	001221020	BOLT 10X20 T	1	
38	030210250	LOCK WASHER M10	1	
39	001210620	BOLT 6X20 H	2	
45	0830000010	COIL SPRING	1	
46	020306050	NUT M6	4	
47	031106100	FLAT WASHER M6	2	
56	502402890	CABLE STOPPER	1	
57	001220820	BOLT 8X20 T	2	
58	030208200	LOCK WASHER M8	2	
59	031108160	FLAT WASHER M8	2	
60	0012-20615	BOLT 6x15 T	4	
64	351010050	GREASE FITTING A-MT6X1	1	
76	001220620	BOLT 6X20 T	1	
87	956300060	THROTTLE LEVER AY 22	1	
88	502303040	THROTTLE WIRE S520-640	1	
89	501310130	LEVER HOLDER	1	
90	001220820	BOLT 8X20 T	2	
91	030208200	LOCK WASHER M8	2	
96	920101200	DECAL, GREASE	1	

# MDR-9GH — ENGINE ASSY.

ENGINE ASSY.



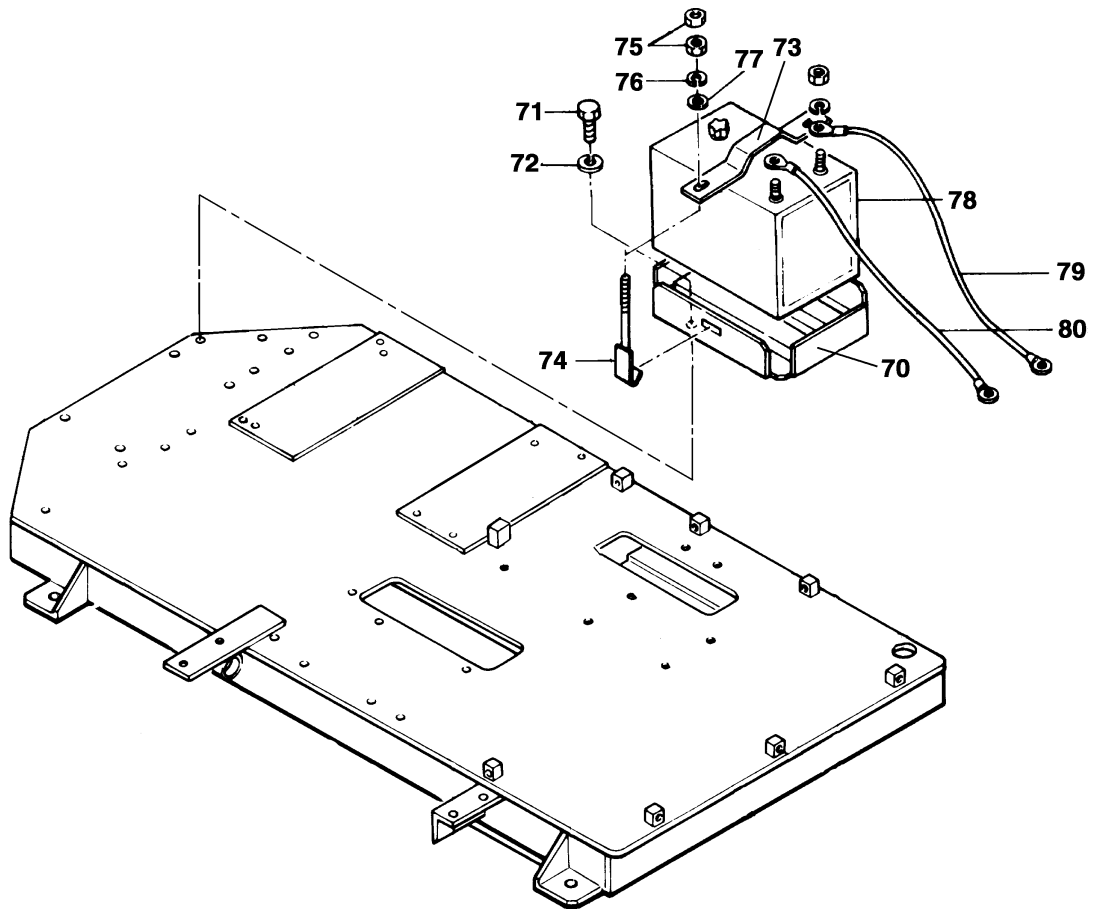


## ENGINE ASSY.

<u>NO.</u>	<u>PART NO.</u>	<u>PART NAME</u>	<u>QTY.</u>	<u>REMARKS</u>
68	912234007	ENGINE, HONDA GX340K1QAE2	1	
69	502403290	KEY 32 X6 32X48	1	
72	031110160	WASHER, FLAT	4	
75	020310080	NUT M10	4	
76	030210250	WASHER, LOCK	4	
77	001221230	BOLT 12X30 T	4	
78	030212300	WASHER, LOCK	4	
79	952400600	WASHER, FLAT 13X28X4.5	4	
80	502454370	PULLEY, ENGINE	1	
81	070200580	V-BELT B-58	2	
82	099208012	SOCKET HEAD SCREW 8X12 T	1	
105	502339880	ENGINE MOUNTING PLATE	1	

# MDR-9GH — BATTERY ASSY.

BATTERY ASSY.

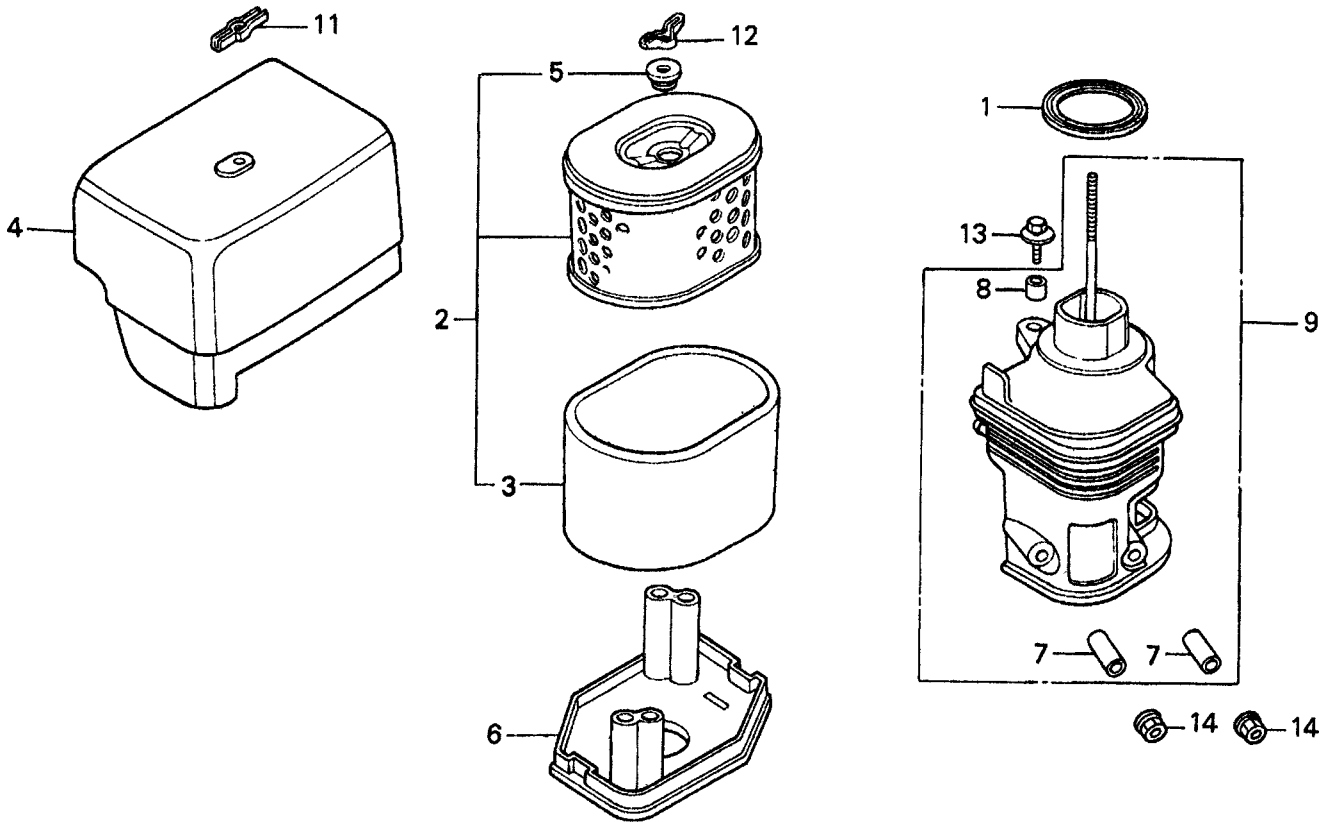


## BATTERY ASSY.

<u>NO.</u>	<u>PART NO.</u>	<u>PART NAME</u>	<u>QTY.</u>	<u>REMARKS</u>
70	502215490	BATTERY BASE (GX340)	1	
71	001200815	BOLT 8X15	4	
72	030208200	WASHER, LOCK M8	4	
73	502403310	BATTERY PROTECT	1	
74	502403320	BOLT/BATTERY	2	
75	020308060	NUT M8	4	
76	030208200	WASHER, LOCK M8	2	
77	031108160	WASHER, FLAT M8	2	
78	607010030	BATTERY 12N24-3.26A19L	1	
79	502301040	BATTERY CORD (+) 220	1	
80	502301050	BATTERY CORD (-) 380	1	

# HONDA GX340K1QAE2 — AIR CLEANER ASSY.

AIR CLEANER ASSY.



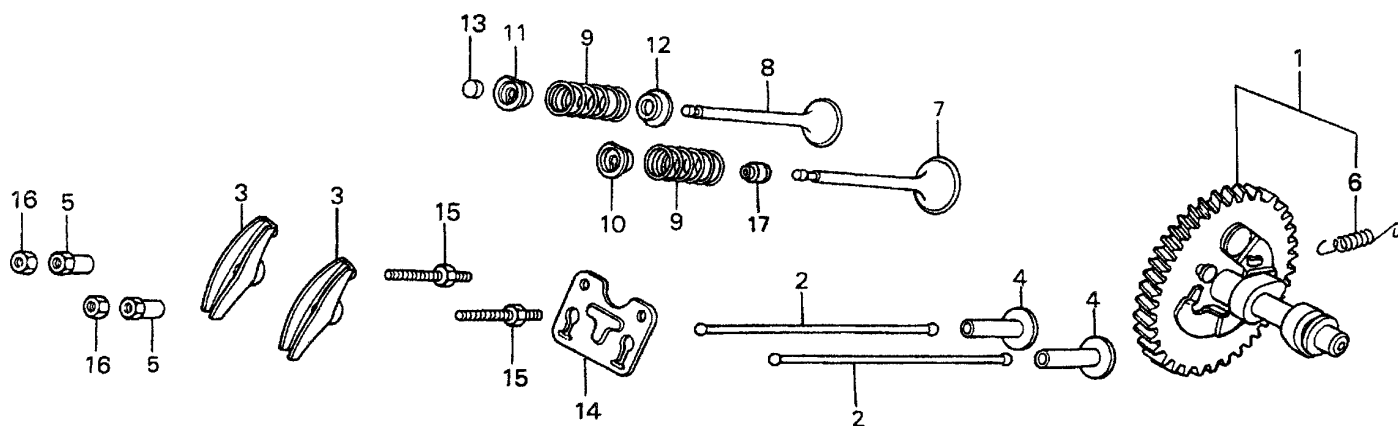
# HONDA GX340K1QAE2 — AIR CLEANER ASSY.

## AIR CLEANER ASSY.

<u>NO.</u>	<u>PART NO.</u>	<u>PART NAME</u>	<u>QTY.</u>	<u>REMARKS</u>
1	16271ZE3010	GASKET, ELBOW	1	
2	17210ZE3505	ELEMENT, AIR CLEANER .....	1	INCLUDES ITEMS W/*
3*	17218ZE3505	FILTER, OUTER	1	
4	17231ZE3W00	COVER, AIR CLEANER	1	
5*	17232891000	GROMMET, AIR CLEANER	1	
6	17235ZH9N00	NOSE, MUFFLER	1	
7#	17238ZE2310	COLLAR, AIR CLEANER	2	
8#	17239ZE1000	COLLAR B, AIR CLEANER	1	
9	17410ZH9N00	ELBOW, AIR CLEANER .....	1	INCLUDES ITEMS W/#
11	90203ZA0800	WINGNUT, 6MM	1	
13	934040602008	BOLT-WASHER, 6X20	1	
14	9405006000	NUT, FLANGE 6MM	2	

# HONDA GX340K1QAE2 — CAMSHAFT ASSY.

CAMSHAFT ASSY.



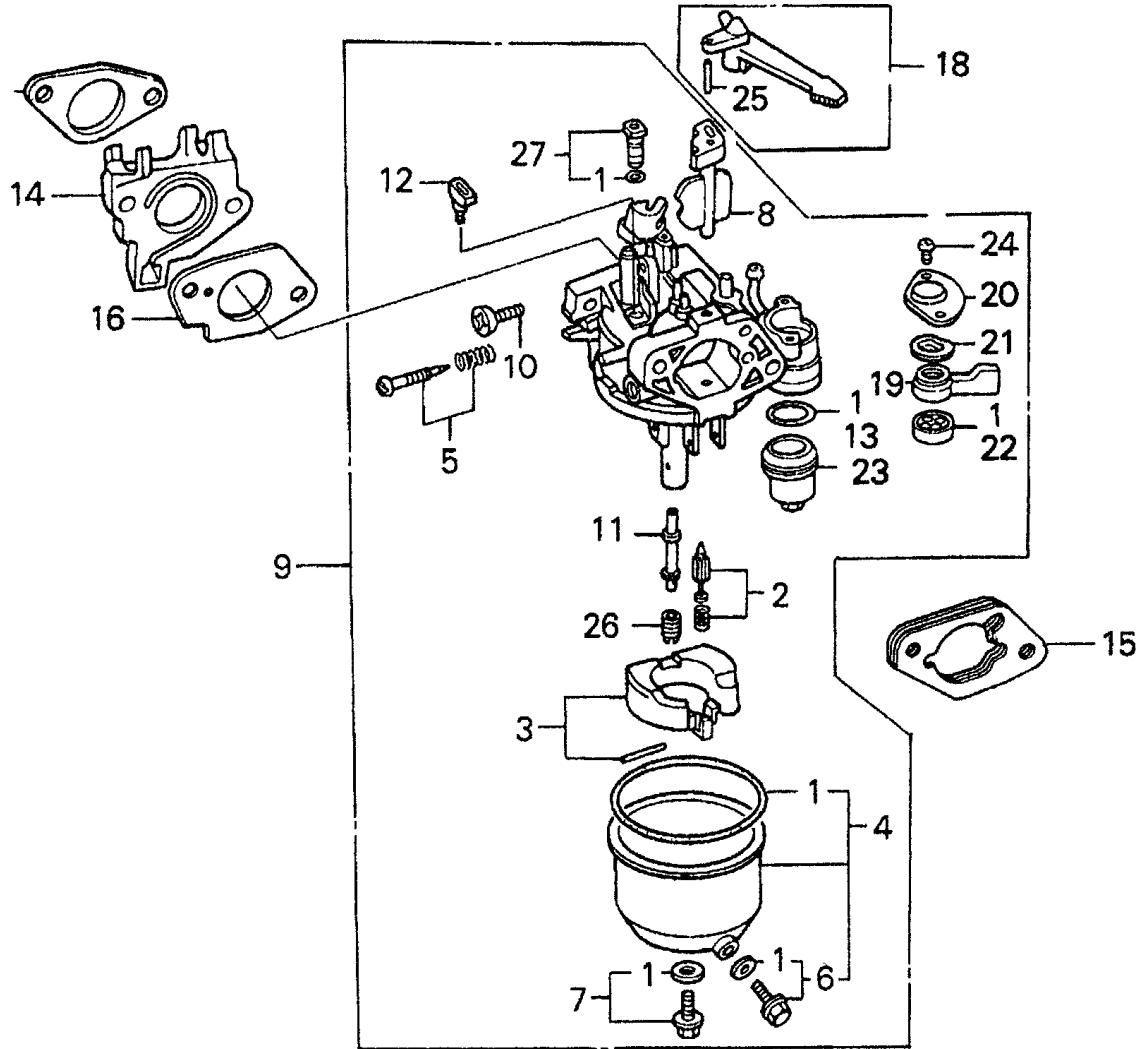
# HONDA GX340K1QAE2 — CAMSHAFT ASSY.

## CAMSHAFT ASSY.

<u>NO.</u>	<u>PART NO.</u>	<u>PART NAME</u>	<u>QTY.</u>	<u>REMARKS</u>
1	14100ZE3020	CAMSHAFT ASSEMBLY .....	1 .....	USE FROM ENGINE SN 2708027 INCLUDES ITEMS W/*
1	14100ZE3305	CAMSHAFT ASSEMBLY .....	1 .....	USE UP TO ENGINE SN 2708026 INCLUDES ITEMS W/*
2	14410ZE3013	ROD, PUSH	2	
3	14431ZE2010	ARM, VALVE ROCKER	2	
4	14441ZE2000	LIFTER, VALVE	2	
5	14451ZE1013	PIVOT, ROCKER ARM	2	
6*	14568ZE1000	SPRING, WEIGHT RETURN	1	
7	14711ZE3000	VALVE, INTAKE	1	
8	14721ZE3000	VALVE, EXHAUST	1	
9	14751ZE2003	SPRING, VALVE	2	
10	14771ZE2000	RETAINER, INTAKE VALVE SPRING	1	
11	14773ZE2000	RETAINER, EXHAUST VALVE SPRING	1	
12	14775ZE2010	SEAT, VALVE SPRING	1	
13	14781ZE2000	ROTATOR, VALVE	1	
14	14791ZE2010	PLATE, PUSH ROD GUIDE	1	
15	90012ZE0010	BOLT, PIVOT 8MM	2	
16	90206ZE1000	NUT, PIVOT ADJ.	2	
17	12209ZE8003	SEAL, VALVE STEM .....	1 .....	USE FROM ENGINE SN 3334264

# HONDA GX340K1QAE2 — CARBURETOR ASSY.

CARBURETOR ASSY.





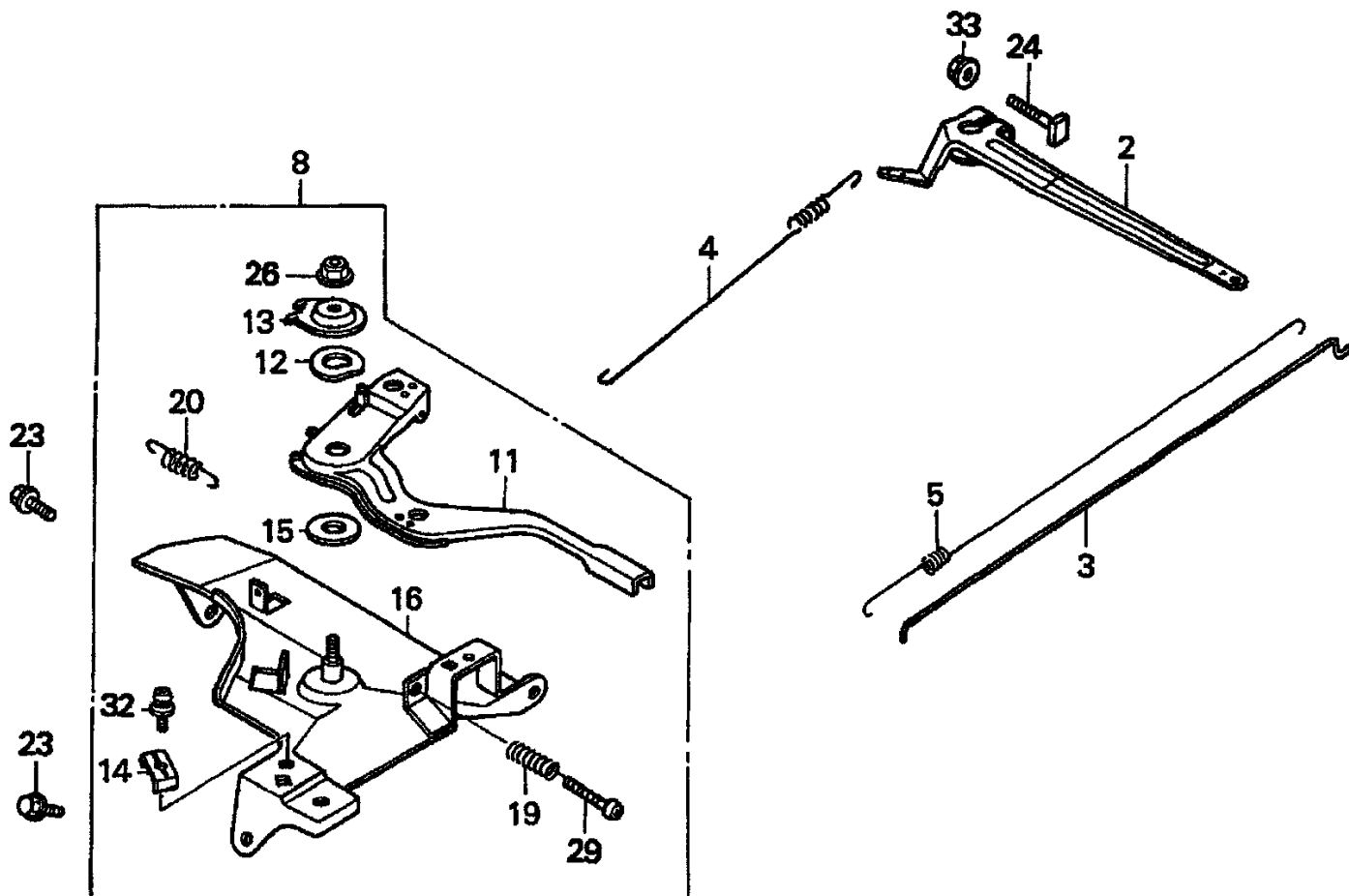
# HONDA GX340K1QAE2 — CARBURETOR ASSY.

## CARBURETOR ASSY.

<u>NO.</u>	<u>PART NO.</u>	<u>PART NAME</u>	<u>QTY.</u>	<u>REMARKS</u>
1*# % +	16010ZE2812	GASKET SET	1	
2*	16011ZA0931	VALVE SET, FLOAT	1	
3*	16013ZA0931	FLOAT SET	1	
4*	16015ZE2005	CHAMBER SET, FLOAT .....	1	INCLUDES ITEMS W/#
4*	16015ZE8005	CHAMBER SET, FLOAT .....	1	INCLUDES ITEMS W/#
6*#	16024ZE1811	SCREW SET, DRAIN	1	
7*	16028ZE0005	SCREW SET B .....	1	INCLUDES ITEM W/ %
8*	16044ZE3811	CHOKE SET	1	
9	16100ZE3V01	CARBURETOR ASSEMBLY, BE80B B ..	1	INCLUDES ITEMS W/*
10	16124ZE0005	SCREW, THROTTLE STOP	1	
11	16166ZE3W50	NOZZLE, MAIN	1	
12	16172ZE3W10	COLLAR, SET	1	
13*	16173001004	GASKET, FUEL STRAINER CUP	1	
14	16211ZE3000	INSULATOR, CARBURETOR	1	
15	16220ZA0702	SPACER, CARBURETOR	1	
16	16221ZE3800	GASKET, CARBURETOR	1	
17	16223ZE3800	GASKET, INSULATOR	1	
18	16610ZE1000	LEVER, CHOKE (STANDARD) .....	1	INCLUDES ITEM W/\$
19*	16953ZE1406	LEVER, VALVE .....	1	USE UP TO ENGINE SN BE80B A
19*	16953ZE1812	LEVER, VALVE .....	1	USE FROM ENGINE SN BE80B B
20*	16954ZE1811	PLATE, LEVER SETTING .....	1	USE UP TO ENGINE SN BE80B A
21	16956ZE1811	SPRING, VALVE LEVER	1	
22*	16957ZE1812	GASKET, VALVE	1	
23*	16967ZE0811	CUP, FUEL STRAINER	1	
24*	93500030060H	SCREW, PAN 3X6 .....	2	USE FROM ENGINE SN BE80B B
24*	93500030080G	SCREW, PAN 3X8 .....	2	USE UP TO ENGINE SN BE80B A
25\$	9430520122	PIN, SPRING 2X12	1	
26*	99101ZH80880	JET, MAIN #88 (OPTIONAL)	1	
26*	99101ZH80900	JET, MAIN #90 (OPTIONAL)	1	
26*	99101ZH80920	JET, MAIN #92	1	
27	99204ZE00350	JET SET, PILOT #35 .....	1	INCLUDES ITEM W/+

# HONDA GX340K1QAE2 — CONTROL ASSY.

CONTROL ASSY.



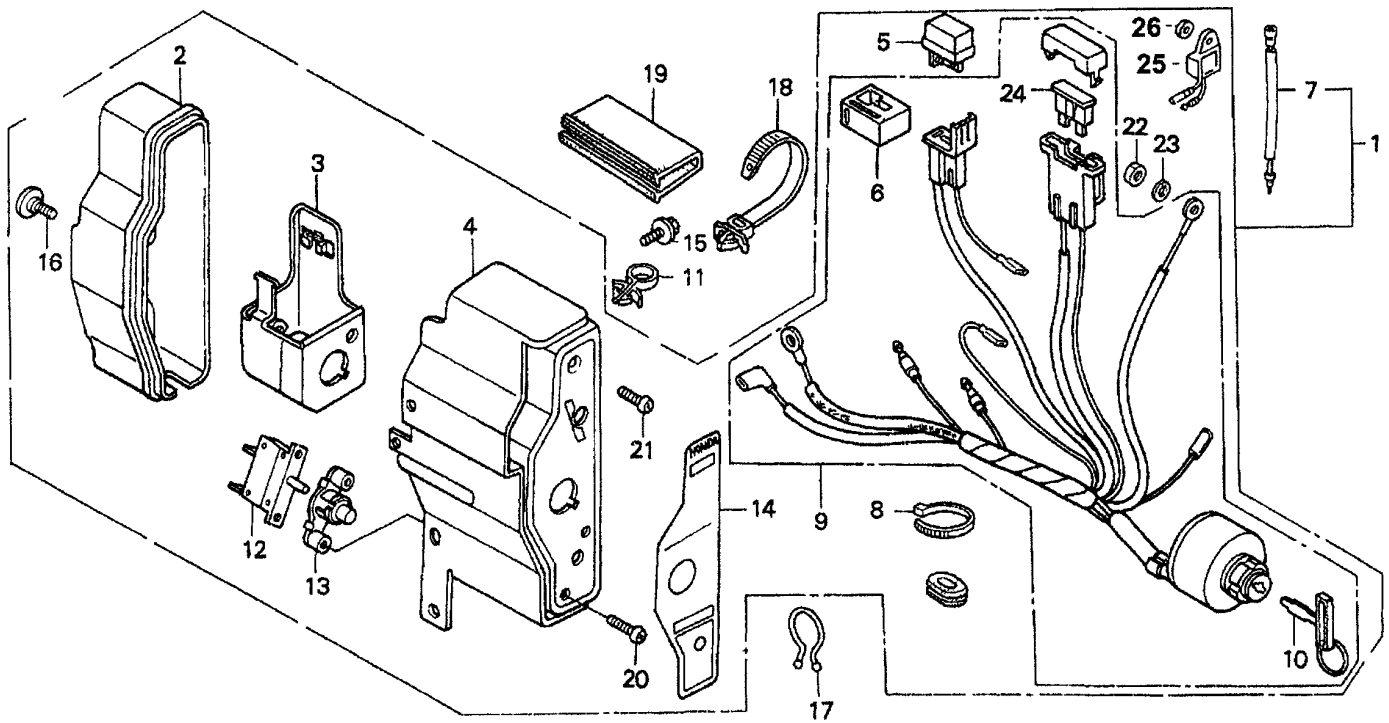
# HONDA GX340K1QAE2 — CONTROL ASSY.

## CONTROL ASSY.

<u>NO.</u>	<u>PART NO.</u>	<u>PART NAME</u>	<u>QTY.</u>	<u>REMARKS</u>
2	16551ZE3000	ARM, GOVERNOR	1	
3	16555ZE3000	ROD, GOVERNOR	1	
4	16561ZE3000	SPRING, GOVERNOR	1	
5	16562ZE3000	SPRING, THROTTLE RETURN	1	
8	16570ZE3W20	CONTROL ASSEMBLY, REMOTE .....	1 .....	INCLUDES ITEMS W/*
11*	16571ze3W00	LEVER CONTROL	1	
12*	16574ZE1000	SPRING, LEVER	1	
13*	16575ZE2W00	WASHER, CONTROL LEVER	1	
14*	16576891000	HOLDER, CABLE	1	
15*	16578ZE1000	SPACER, CONTROL LEVER	1	
16*	16581ZE3W00	BASE CONTROL	1	
19*	16584883300	SPRING, CONTROL ADJUSTING	1	
20*	16592883310	SPRING, CABLE RETURN	1	
23	90013883000	BOLT, FLANGE 6X12 (CT200)	2	
24	90015ZE5010	BOLT, GOVERNOR ARM	1	
26*	90114SA0000	NUT, SELF- LOCK 6MM	1	
29*	93500050320A	SCREW, PAN 5X32	1	
32*	93500050160A	SCREW, PAN 5X16	1	
33	9405006000	NUT, FLANGE 6MM	1	

# HONDA GX340K1QAE2 — CONTROL BOX ASSY.

CONTROL BOX ASSY.



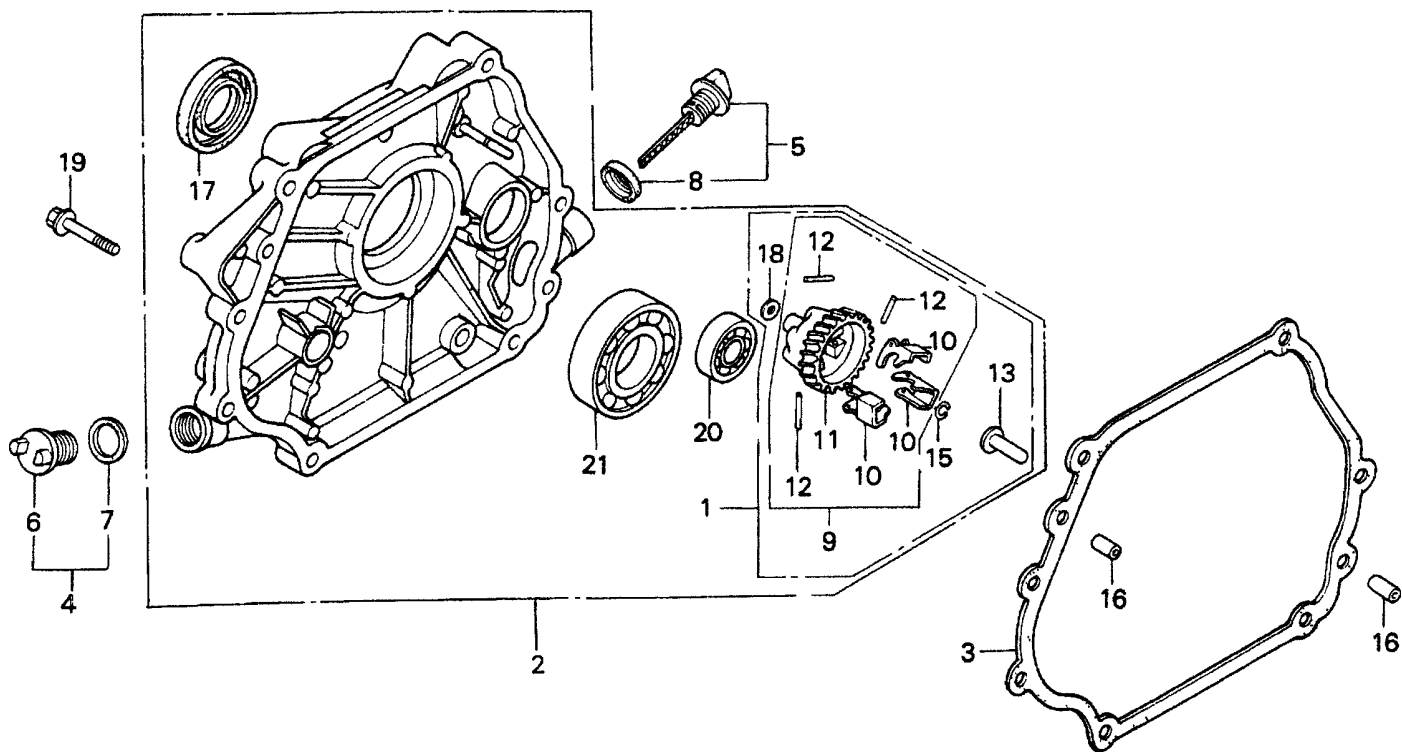
# HONDA GX340K1QAE2 — CONTROL BOX ASSY.

## CONTROL BOX ASSY.

<u>NO.</u>	<u>PART NO.</u>	<u>PART NAME</u>	<u>QTY.</u>	<u>REMARKS</u>
1	31610ZE3W23ZB	BOX ASSY., CONTROL (EXTERNAL-ALERT/3A) *R8* BRIGHT RED	1	INCLUDES ITEMS W/*
2*	31612ZE2003	CASE, CONTROL	1	
3*	31614ZE2003	BRACKET, CASE MOUNTING	1	
4*	31615ZE3003ZB	PANEL, CONTROL *R8* BRIGHT RED	1	
5*	31700124003	RECTIFIER ASSY., SILICON (STANLEY)	1	
6*#	32127738700	SUSPENSION, CONNECTOR	1	
7*	32197ZE1003	SUB- HARNESS	1	
8	32902892003	BAND	1	
9*	35100ZE2842	SWITCH ASSEMBLY, COMBINATION	1	INCLUDES ITEMS W/#
10*#	35111880003	KEY	1	
11	36103ZE1000	HOLDER, STOP SWITCH WIRE	1	
12*	38240ZE2840	PROTECTOR, CIRCUIT 3.5A	1	
13*	38250ZA8701	LENS ASSEMBLY, PROTECTOR	1	
14*	87529ZE2811	PANEL, CONTROL BOX (EXTERNAL)	1	
15	90013883000	BOLT, FLANGE 6X12 (CT200)	1	
16*	90380MA6010	SCREW, SPECIAL 6X12	1	
17	90630751000	CLIP, PURSE LOCK	1	
18	90672SA0003	STRAP, CABLE 118MM *NHL* BLACK	1	
19	91406ZE2003	TUBE, FASTENER 30	1	
20*	93500030120H	SCREW, PAN 3X12	2	
21*	93500040120H	SCREW, PAN 4X12	1	
22*	94001043900S	NUT, HEX. 4MM	2	USE FROM ENGINE SN 2801238
23*	9411104800	WASHER, SPRING 4MM	1	
24*#	9820031500	FUSE, BLADE 15A	1	
25*	34150ZH7003	ALERT UNIT, OIL	1	USE FROM ENGINE SN 2801238
26*	9410104800	WASHER, PLAIN 4MM	1	USE FROM ENGINE SN 2801238

# HONDA GX340K1QAE2 — CRANKCASE COVER ASSY.

CRANKCASE COVER ASSY.



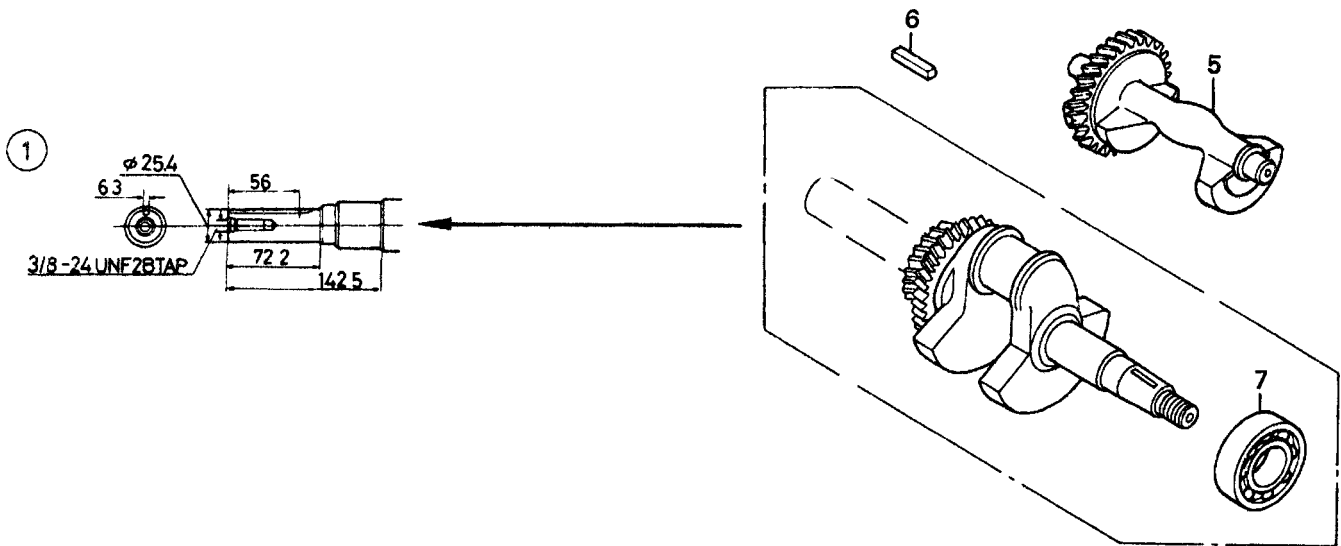
# HONDA GX340K1QAE2 — CRANKCASE COVER ASSY.

## CRANKCASE COVER ASSY.

<u>NO.</u>	<u>PART NO.</u>	<u>PART NAME</u>	<u>QTY.</u>	<u>REMARKS</u>
1*	06165ZE3000	GOVERNOR KIT, OPTIONAL .....	1 .....	INCLUDES ITEMS W/#
2	11300ZE3602	COVER ASSY., CRANKCASE (Q TYPE) .....	1 .....	INCLUDES ITEMS W/*
3	11381ZE3800	GASKET, CASE COVER	1	
3	11381ZE3801	GASKET, CASE COVER	1	
4	15600ZG4003	CAP ASSEMBLY OIL FILLER	1	
5	15600735003	CAP ASSEMBLY OIL FILLER	1	
7	15625ZE1003	GASKET, OIL FILLER CAP	1	
8	15625ZE1003	GASKET, OIL FILLER CAP	1	
9*#	16510ZE3000	GOVERNOR ASSEMBLY .....	1 .....	INCLUDES ITEMS W/%
10*#%	16511ZE8000	WEIGHT, GOVERNOR	3	
11*#%	16512ZE3000	HOLDER, GOVERNOR WEIGHT	1	
12*#%	16513ZE2000	PIN, GOVERNOR WEIGHT	3	
13*#	16531ZE2000	SLIDER, GOVERNOR	1	
15*#	90602ZE1000	CLIP, GOVERNOR HOLDER	1	
16	90701HC4000	PIN, DOWEL 8X12	2	
17*	91201ZE3004	OIL SEAL 35X52X8	1	
18*#	9410106800	WASHER, PLAIN 6MM	1	
19	957010804000	BOLT, FLANGE 8X40	7	
20*	961006202000	BEARING, RADIAL BALL 6202	1	
21*	961006207000	BEARING, RADIAL BALL 6207	1	

# HONDA GX340K1QAE2 — CRANKSHAFT ASSY.

CRANKSHAFT ASSY.





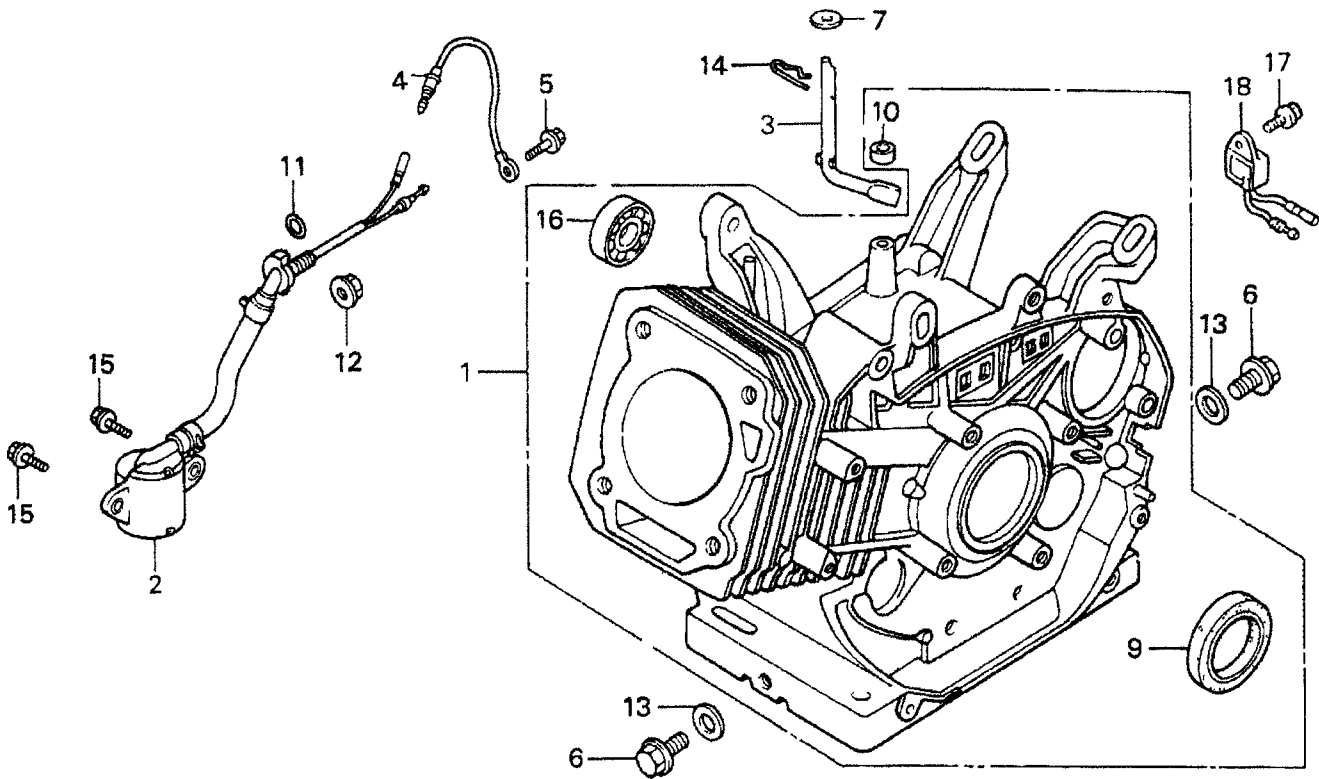
## HONDA GX340K1QAE2 — CRANKSHAFT ASSY.

### CRANKSHAFT ASSY.

<u>NO.</u>	<u>PART NO.</u>	<u>PART NAME</u>	<u>QTY.</u>	<u>REMARKS</u>
1	13310ZE3601	CRANKSHAFT, Q- TYPE	1	
5	13351ZE3010	WEIGHT, BALANCER	1	
6	90745ZE2600	KEY 6.3X6.3X43	1	
7	961006207000	BEARING, RADIAL BALL 6207	1	

# HONDA GX340K1QAE2 — CYLINDER BARREL ASSY.

CYLINDER BARREL ASSY.



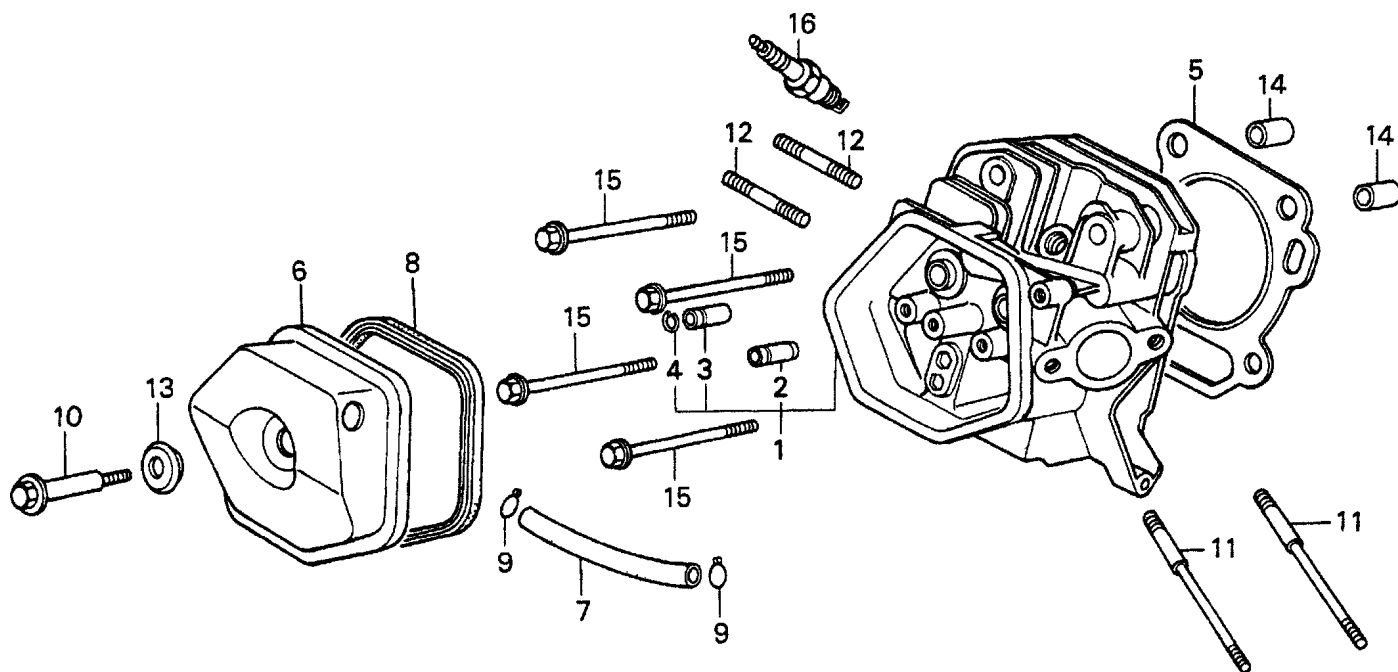
# HONDA GX340K1QAE2 — CYLINDER BARREL ASSY.

## CYLINDER BARREL ASSY.

<u>NO.</u>	<u>PART NO.</u>	<u>PART NAME</u>	<u>QTY.</u>	<u>REMARKS</u>
1	12000ZE3826	CYLINDER ASSY., (SELF STARTER..... + ALERT)	1	INCLUDES ITEMS W/*
2	15510ZE2043	SWITCH ASSEMBLY, OIL LEVEL	1	
3	16541ZE3010	SHAFT, GOVERNOR ARM	1	
4	32197ZE2003	SUB- HARNESS .....	1	USE UP TO ENGINE SN 2639737
5	90013883000	BOLT, FLANGE 6X12 (CT200) .....	1	USE UP TO ENGINE SN 2639737
6	90131883000	BOLT, DRAIN PLUG	2	
6	90131896650	BOLT, DRAIN PLUG	2	
7	90446KE1000	WASHER 8.2X17X0.8	1	
9*	91201ZE3004	OIL SEAL 35X52X8	1	
10	91201ZE9003	OIL SEAL 8X14X5	1	
10	91203952771	OIL SEAL 8X14X5	1	
11	91353671003	O- RING 13.5X1.5 (ARAI)	1	
12	9405010000	NUT, FLANGE 10MM	1	
13	9410912000	WASHER, DRAIN PLUG 12MM	2	
14	9425110000	PIN, LOCK 10MM	1	
15	957010601200	BOLT, FLANGE 6X12	2	
16*	961006202000	BEARING, RADIAL BALL 6202	1	

# HONDA GX340K1QAE2 — CYLINDER HEAD ASSY.

CYLINDER HEAD ASSY.



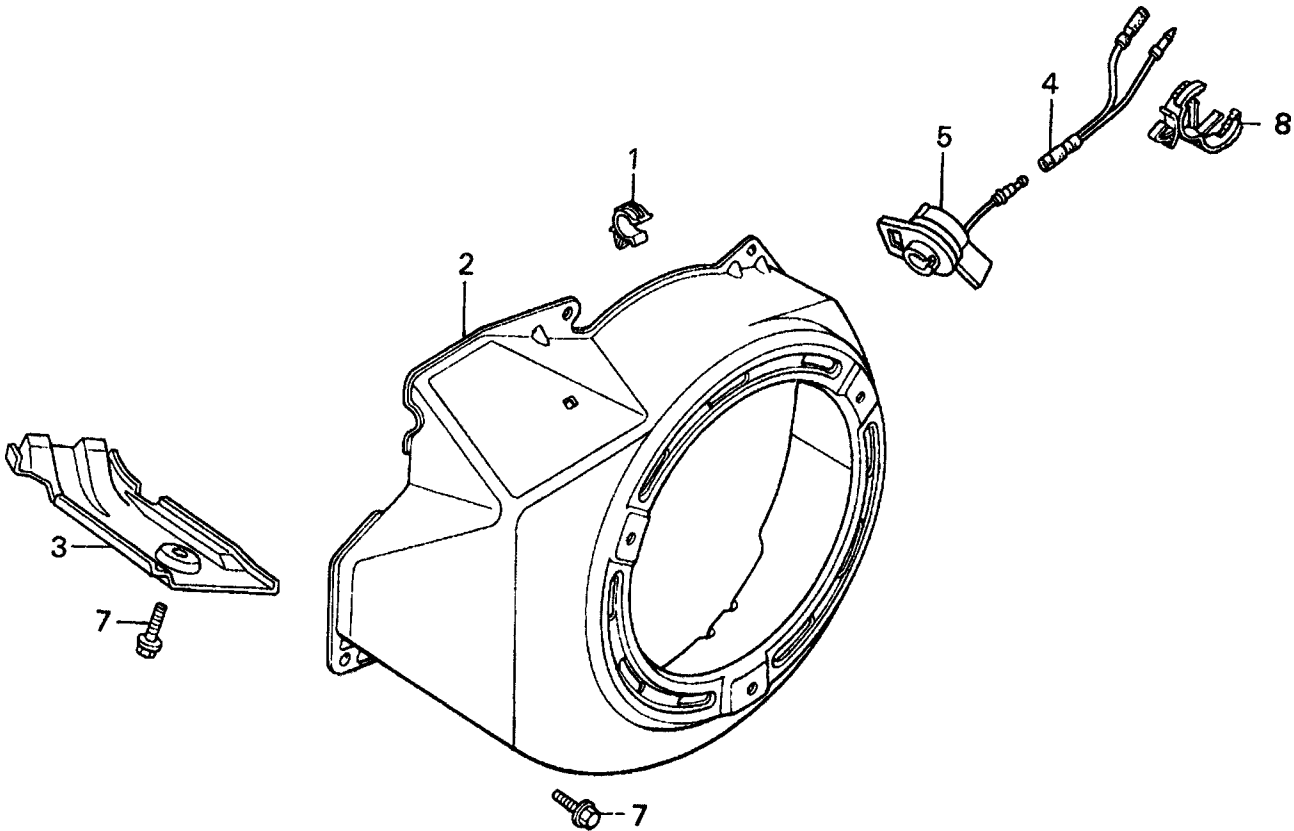
# HONDA GX340K1QAE2 — CYLINDER HEAD ASSY.

## CYLINDER HEAD ASSY.

<u>NO.</u>	<u>PART NO.</u>	<u>PART NAME</u>	<u>QTY.</u>	<u>REMARKS</u>
1	12200ZF6W00	CYLINDER HEAD .....	1 .....	INCLUDES ITEMS W/*
1	12200ZF6W01	CYLINDER HEAD .....	1 .....	INCLUDES ITEMS W/*
2*	12204ZE2306	GUIDE, VALVE OS (OPTIONAL)	1	
3*	12205ZE2305	GUIDE, EXHAUST VALVE OS (OPT.)	1	
4*	12216ZE2300	CLIP, VALVE GUIDE	1	
5	12251ZE3W00	GASKET, CYLINDER HEAD	1	
6	12310ZE3791	COVER, HEAD	1	
7	12315ZE3840	TUBE, BREATHER	1	
8	12391ZE2020	GASKET, CYLINDER HEAD COVER	1	
10	90014ZE2000	BOLT, HEAD COVER	1	
11	90042ZE8000	BOLT, STUD 8X131.5	2	
12	90047ZE2000	BOLT, STUD 8X47 .....	2 .....	USE UP TO ENGINE SN 3033461
12	92900080320E	BOLT 2, STUD 8X32 .....	2 .....	USE FROM ENGINE SN 3033462
13	90441ZE2010	WASHER, HEAD COVER	1	
14	9430112200	PIN A, DOWEL 12X20	2	
15	957011008000	BOLT, FLANGE 10X80	4	
15	957251008000	BOLT, FLANGE 10X80	4	
16	9807955846	SPARK PLUG BPR5ES (NGK) (OPT.)	1	
16	9807955855	SPARK PLUG W16EPR-U (DENSO) (OPT.)	1	
16	9807956846	SPARK PLUG BPR6ES (NGK)	1	
16	9807956855	SPARK PLUG W20EPR- U (DENSO)	1	

# HONDA GX340K1QAE2 — FAN COVER ASSY.

FAN COVER ASSY.



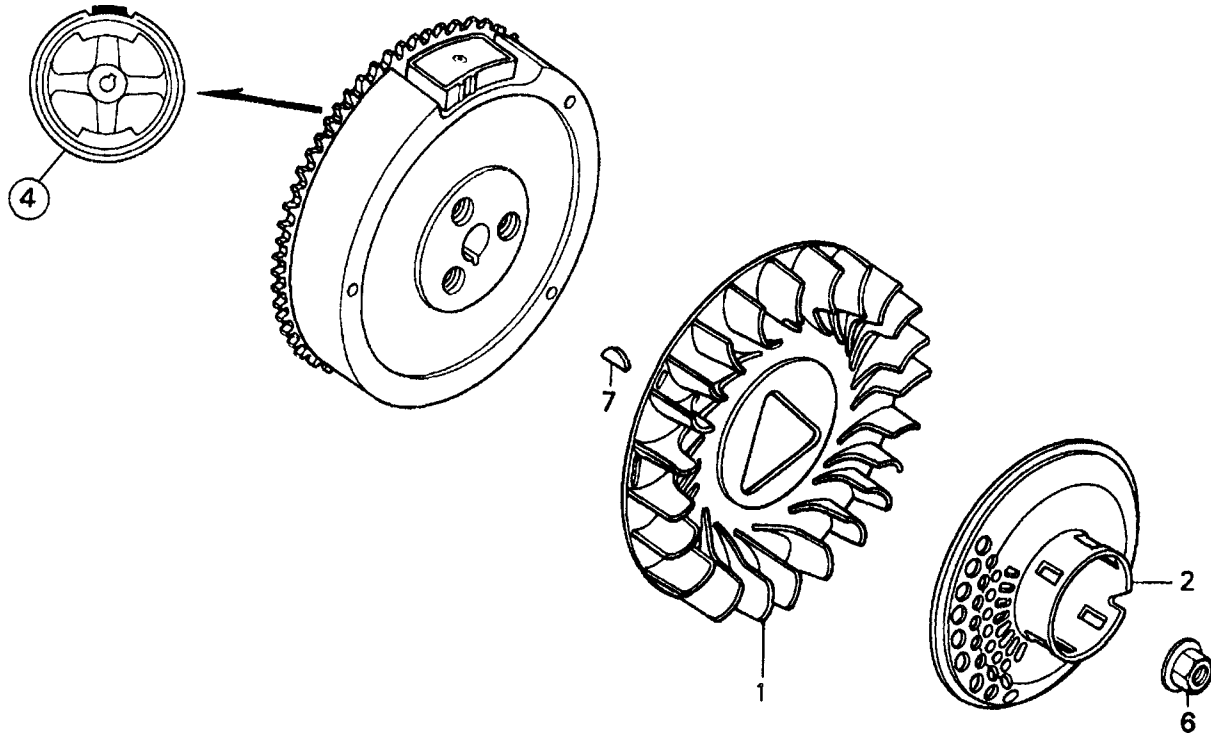
# HONDA GX340K1QAE2 — FAN COVER ASSY.

FAN COVER ASSY.

<u>NO.</u>	<u>PART NO.</u>	<u>PART NAME</u>	<u>QTY.</u>	<u>REMARKS</u>
1	16731ZE2003	CLIP, TUBE	1	
2	19610ZE3010ZA	COVER, FAN *R8* BRIGHT RED	1	
3	19631ZE3W00	SHROUD	1	
6	81329567020	GROMMET, DRAIN HOLE	1	
7	90013883000	BOLT, FLANGE 6X12 (CT200)	6	

# HONDA GX340K1QAE2 — FLYWHEEL ASSY.

FLYWHEEL ASSY.





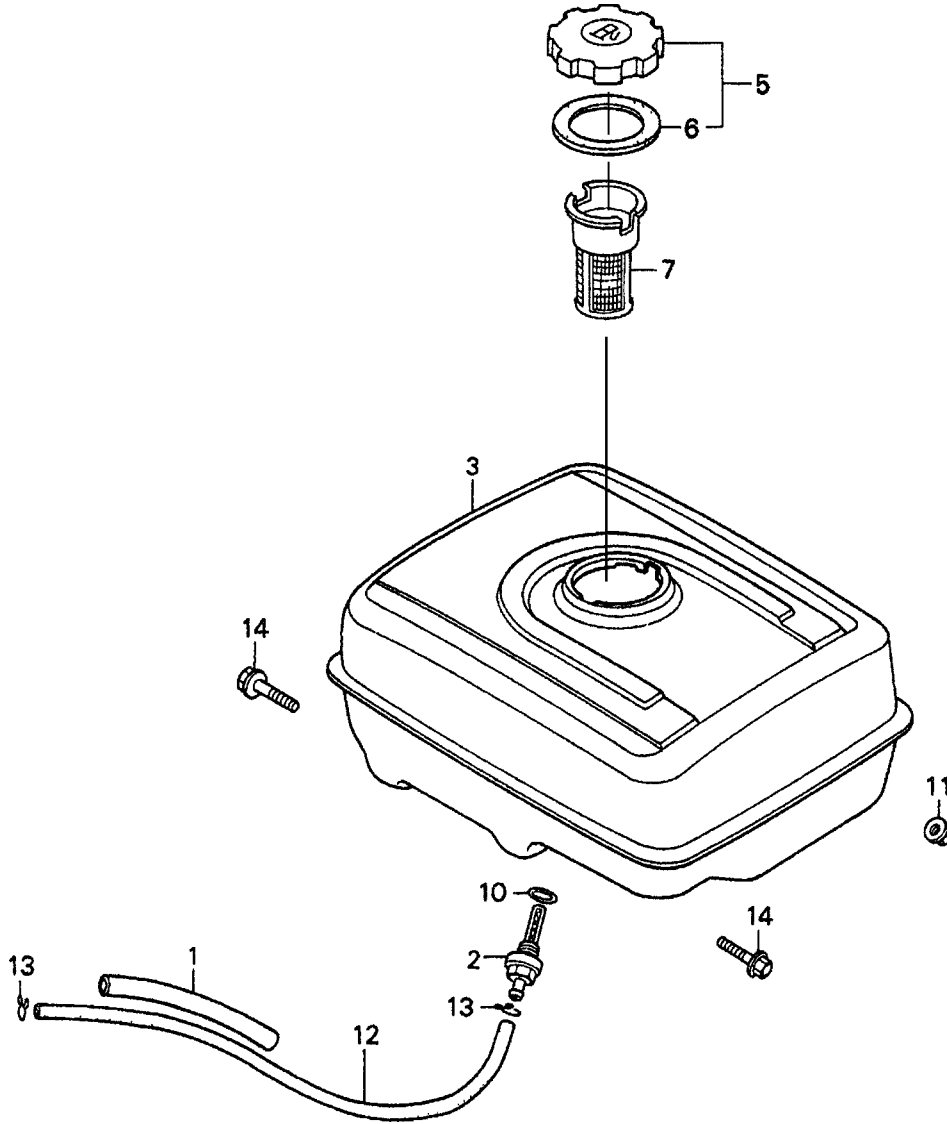
# HONDA GX340K1QAE2 — FLYWHEEL ASSY.

FLYWHEEL ASSY.

<u>NO.</u>	<u>PART NO.</u>	<u>PART NAME</u>	<u>QTY.</u>	<u>REMARKS</u>
1	19511ZE3000	FAN, COOLING	1	
2	28450ZE3W11	PULLEY, STARTER (SCREEN GRID)	1	
3	31100ZE3W01	FLYWHEEL, 4 POLE	1	
6	90201ZE3V00	NUT, SPECIAL 16MM (1) .....	1	USE FROM ENGINE SN 2536523
6	90201ZE3790	NUT, SPECIAL 16MM .....	1	USE UP TO ENGINE SN 2536522
7	90741ZE2000	KEY, SPECIAL WOODRUFF 25X18	1	

# HONDA GX340K1QAE2 — FUEL TANK ASSY.

FUEL TANK ASSY.



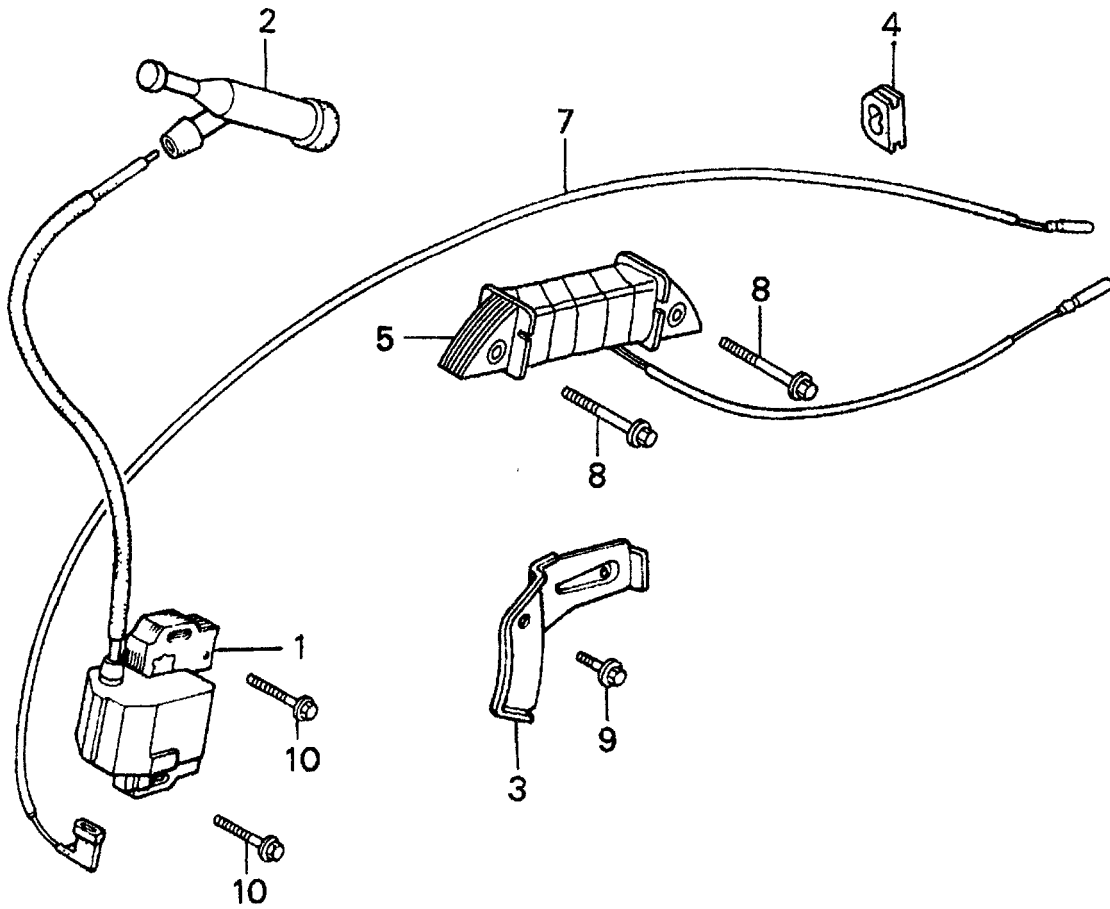
# HONDA GX340K1QAE2 — FUEL TANK ASSY.

## FUEL TANK ASSY.

<u>NO.</u>	<u>PART NO.</u>	<u>PART NAME</u>	<u>QTY.</u>	<u>REMARKS</u>
1	16854ZH8000	RUBBER, SUPPORTER 107MM	1	
2	16955ZE1000	JOINT, FUEL TANK	1	
3	17510ZE3010ZA	TANK, FUEL *NH31* MCKINLEY WHITE	1	
5	17620ZH7023	CAP, FUEL FILLER .....	1	USE UP TO ENGINE SN 4122402 INCLUDES ITEMS W/*
5	17620ZH7023	CAP, FUEL FILLER .....	1	USE FROM ENGINE SN 4122403 INCLUDES ITEMS W/*
6*	17631ZH7003	GASKET, FUEL FILLER CAP	1	
7	17672ZE2W01	FILTER, FUEL	1	
10	91353671003	O- RING 13.5X1.5 (ARAI)	1	
11	9405008000	NUT, FLANGE 8MM	2	
12	950014500360M	BULK HOSE, FUEL (4.5X3000) (4.5X235)	1	
13	9500202080	CLIP, TUBE B8	2	
14	957010802500	BOLT, FLANGE 8X25	2	

# HONDA GX340K1QAE2 — IGNITION COIL ASSY.

IGNITION COIL ASSY.



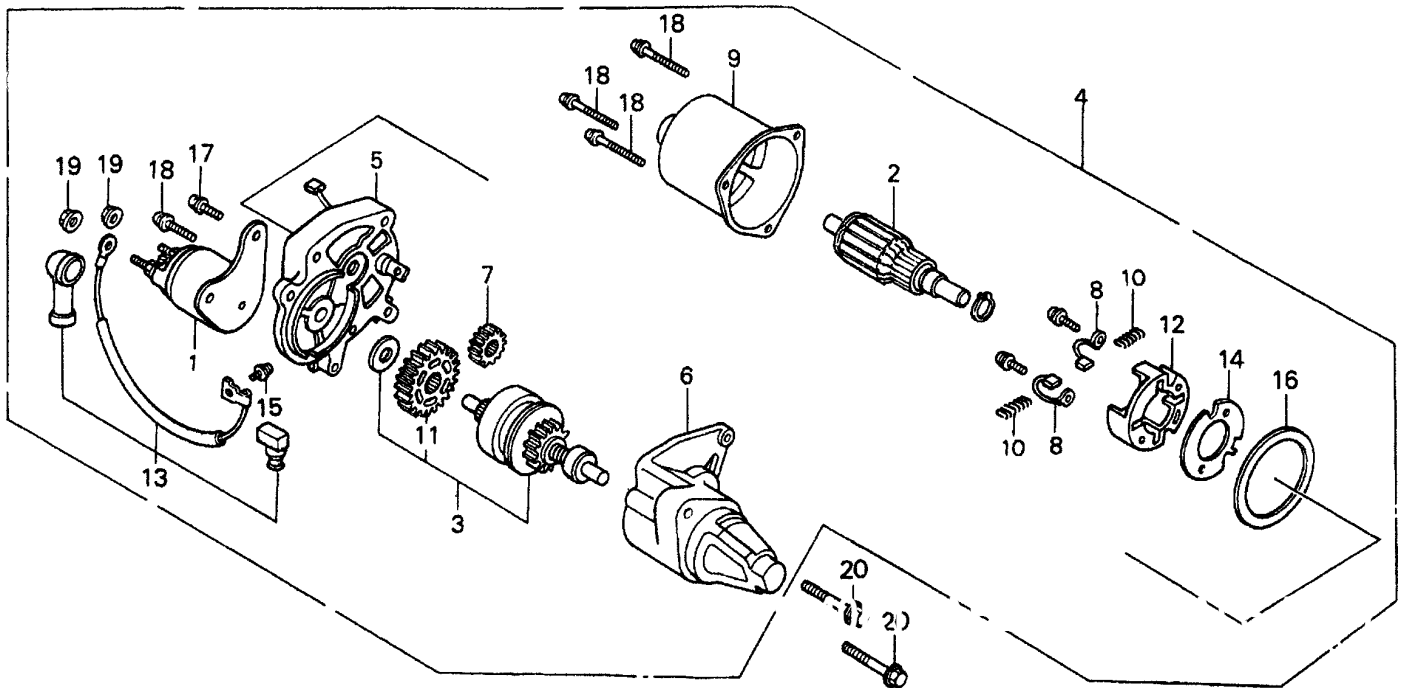
## HONDA GX340K1QAE2 — IGNITION COIL ASSY.

### IGNITION COIL ASSY.

<u>NO.</u>	<u>PART NO.</u>	<u>PART NAME</u>	<u>QTY.</u>	<u>REMARKS</u>
1	30500ZE2023	COIL ASSEMBLY, IGNITION	1	
2	30700ZE1013	CAP ASSEMBLY, NOISE SUPPRESSOR	1	
3	31511ZE3000	CLAMP, WIRE	1	
4	31512ZE2000	GROMMET, WIRE	1	
5	31630ZE2841	COIL ASSEMBLY, CHARGE (3A)	1	
7	36101ZE2701	WIRE, STOP SWITCH 430MM	1	
8	90012888000	BOLT, FLANGE 6X40	2	
9	90013883000	BOLT, FLANGE 6X12 (CT200)	1	
10	90015883000	BOLT, FLANGE 6X28	2	

# HONDA GX340K1QAE2 — STARTER MOTOR ASSY.

STARTER MOTOR ASSY.



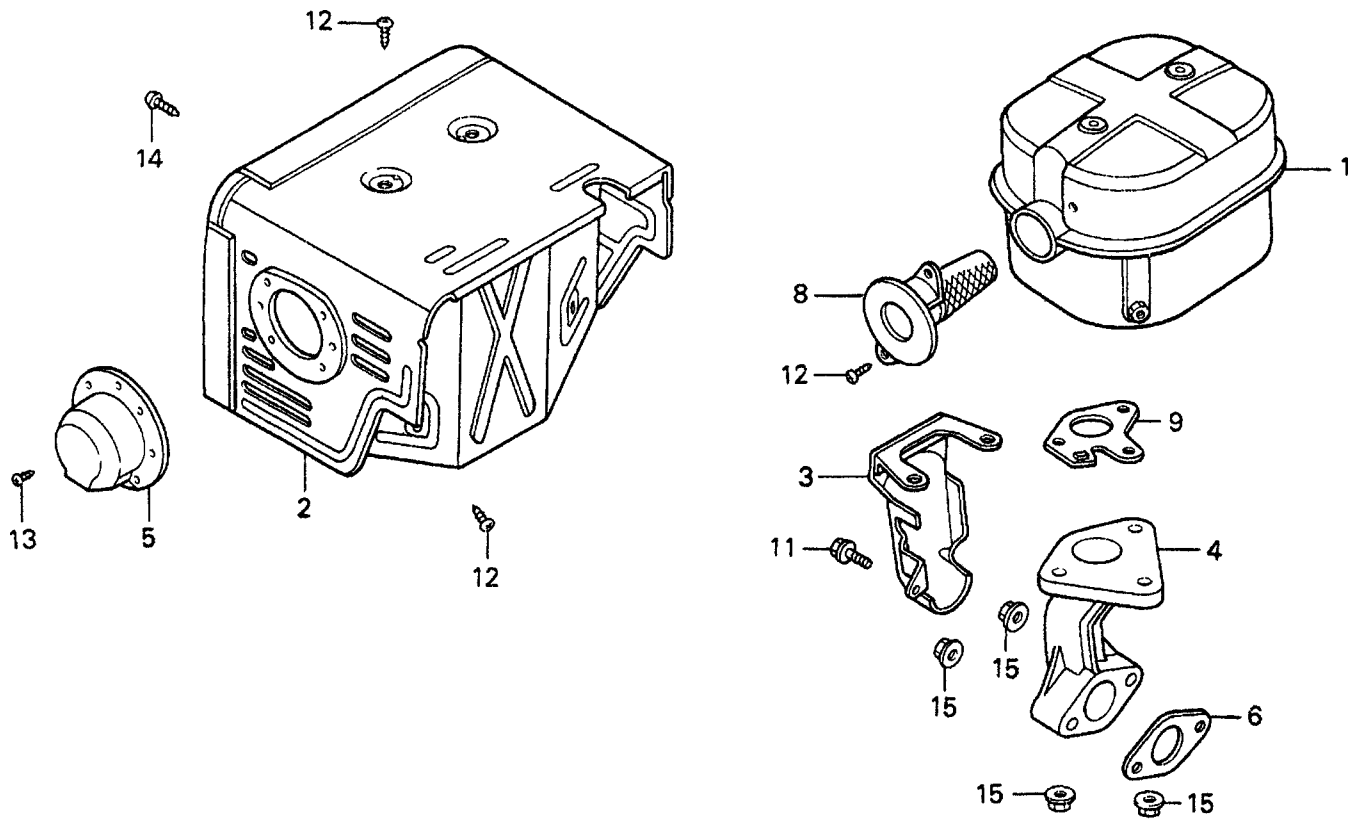
# HONDA GX340K1QAE2 — STARTER MOTOR ASSY.

## STARTER MOTOR ASSY.

<u>NO.</u>	<u>PART NO.</u>	<u>PART NAME</u>	<u>QTY.</u>	<u>REMARKS</u>
1*	31204ZA0003	CONTACTOR ASSEMBLY	1	
2*	31206ZE3003	ARMATURE	1	
3*	31207ZE3003	CLUTCH, OVERRUNNING	1	
4	31201ZE3013	MOTOR UNIT, STARTER .....	1	INCLUDES ITEMS W/*
5*	31211ZE2003	BRACKET, CENTER	1	
6*	31212ZE3003	BRACKET, FRONT	1	
7*	31213ZE2003	GEAR, DRIVE PINION	1	
8*	31215ZE2003	BRUSH	2	
9*	31218ZE3003	YOKE	1	
10*	31219ZE2003	SPRING, BRUSH RETURN	4	
11*	31222ZE3791	GEAR, REDUCTION	1	
12*	31231ZE2003	HOLDER, BRUSH	1	
13*	31232ZE3003	WIRE, WATER COVER	1	
14*	31233ZE2003	INSULATOR	1	
15*	90110ZE2003	SCREW- WASHER 4X6	1	
16*	91601ZE2003	GASKET	1	
17*	90007ZE2003	BOLT- WASHER 5X14 .....	2	USE FROM ENGINE SN 2630807
17*	938920501408	SCREW- WASHER 5X14 .....	2	USE UP TO ENGINE SN 2630806
18*	938920503208	SCREW- WASHER 5X3	4	
19*	9407006080	NUT- WASHER 6MM	2	
20	957010803508	BOLT, FLANGE 8X35	2	

# HONDA GX340K1QAE2 — MUFFLER ASSY.

MUFFLER ASSY.





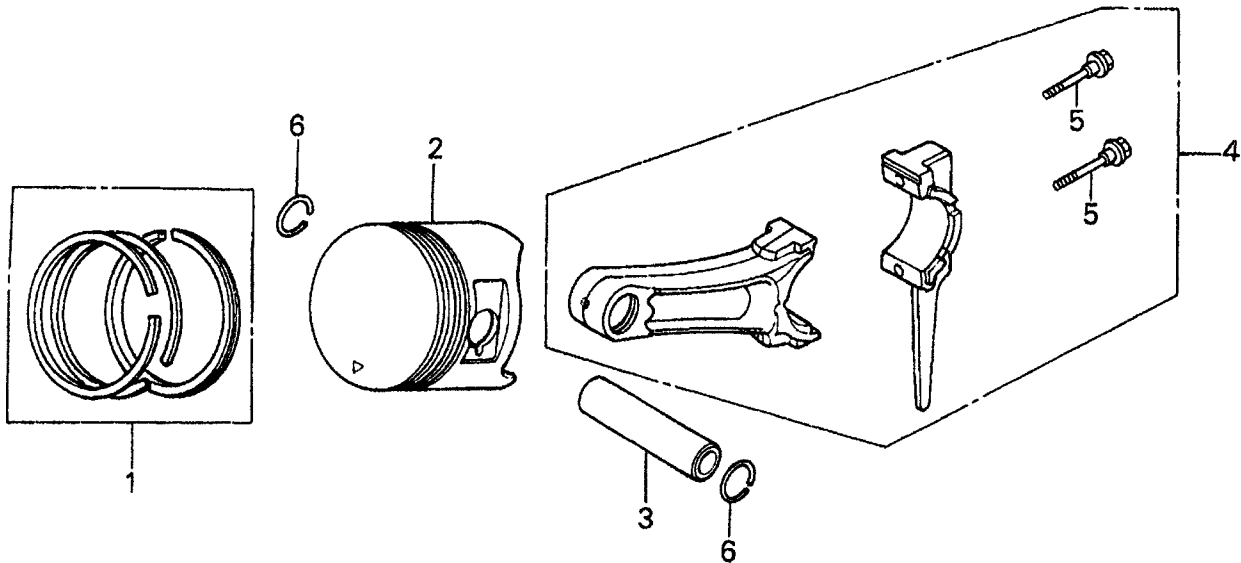
# HONDA GX340K1QAE2 — MUFFLER ASSY.

## MUFFLER ASSY.

<u>NO.</u>	<u>PART NO.</u>	<u>PART NAME</u>	<u>QTY.</u>	<u>REMARKS</u>
1	18310ZE3W00	MUFFLER	1	
2	18320ZE3W01	PROTECTOR, MUFFLER	1	
3	18323ZE3W40	PROTECTOR, EXHAUST PIPE	1	
4	18330ZE2W00	PIPE, EXHAUST	1	
5	18331ZE3810	CAP, MUFFLER	1	
6	18333ZF6W01	GASKET, EXHAUST PIPE .....	1	..... USE FROM ENGINE SN 3030998
6	18333ZK6Y00	GASKET, EXHAUST PIPE (WACKER) .....	1	..... USE UP TO ENGINE SN 3030997
8	18355ZE2W10	ARRESTER, SPARK	1	
9	18381ZE2W10	GASKET, MUFFLER (ARRESTER)	1	
11	90013883000	BOLT, FLANGE 6X12 (CT200)	1	
12	90050ZE1000	SCREW, TAPPING 5X8	6	
13	90055ZE1000	SCREW, TAPPING 4X6	3	
14	93500060060B	SCREW, PAN 6X6	1	
15	9405008000	NUT, FLANGE 8MM	5	

# HONDA GX340K1QAE2 — PISTON ASSY.

PISTON ASSY.



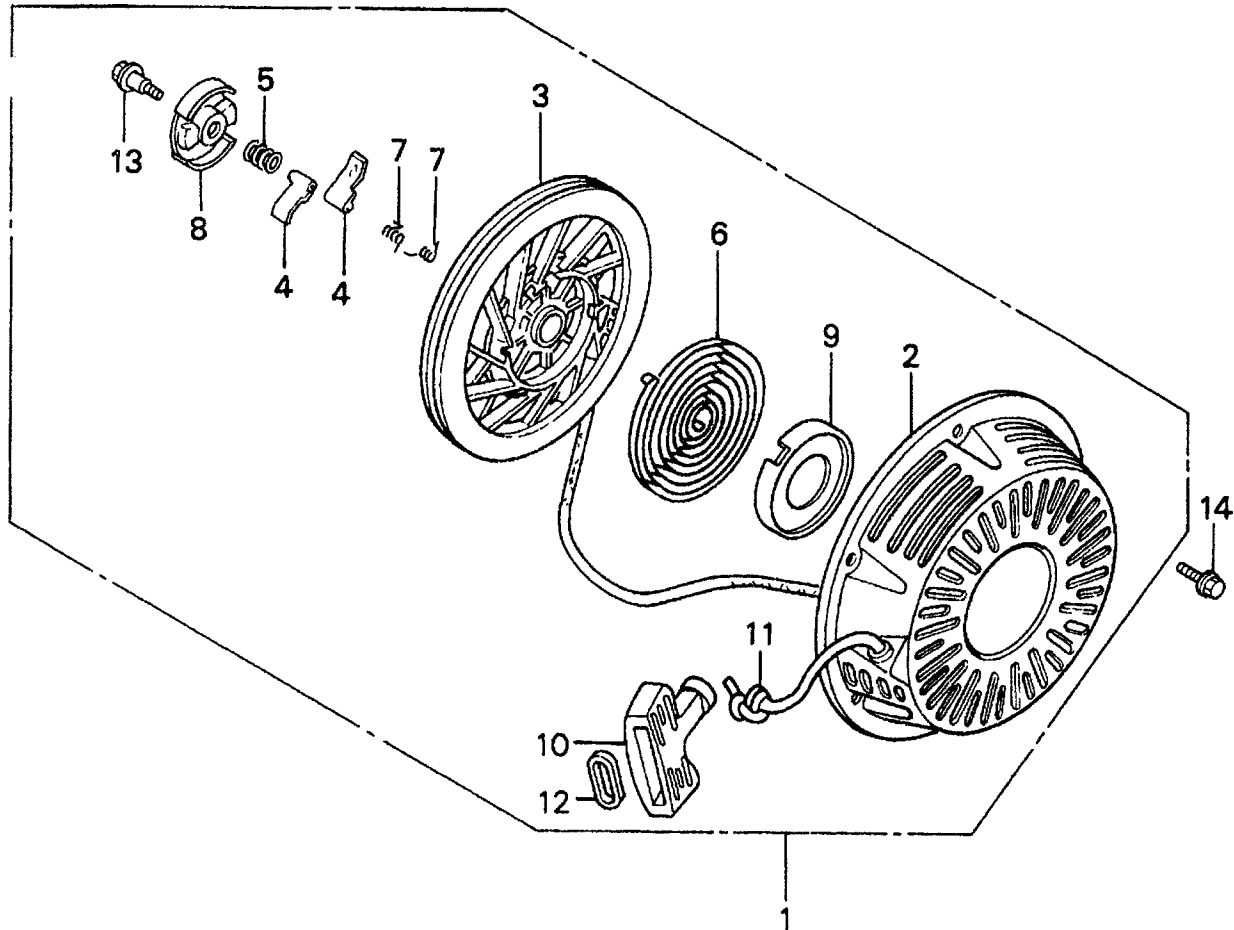
## HONDA GX340K1QAE2 — PISTON ASSY.

### PISTON ASSY.

<u>NO.</u>	<u>PART NO.</u>	<u>PART NAME</u>	<u>QTY.</u>	<u>REMARKS</u>
1	13010ZE3003	RING SET, PISTON (STANDARD)	1	
1	13011ZE3003	RING SET, PISTON (OS 0.25) (OPT.)	1	
1	13012ZE3003	RING SET, PISTON (OS0.50) (OPT.)	1	
1	13013ZE3003	RING SET, PISTON (0.75) (OPTIONAL)	1	
2	13101ZE3W00	PISTON, STANDARD	1	
2	13102ZE3W00	PISTON, OS 0.25 (OPTIONAL)	1	
2	13103ZE3W00	PISTON, OS 0.50 (OPTIONAL)	1	
2	13104ZE3W00	PISTON, 0.75 (OPTIONAL)	1	
3	13111ZF6000	PIN, PISTON	1	
4	13200ZE3010	ROD ASSEMBLY, CONNECTING (STD.)	1	
4	13200ZE3315	ROD ASSEMBLY CONNECTING (US 0.25) OPTIONAL	1	
5	90001ZE8000	BOLT, CONNECTING ROD	2	
6	90601ZE3000	CLIP, PISTON PIN 20MM	2	

# HONDA GX340K1QAE2 — RECOIL STARTER ASSY.

RECOIL STARTER ASSY.



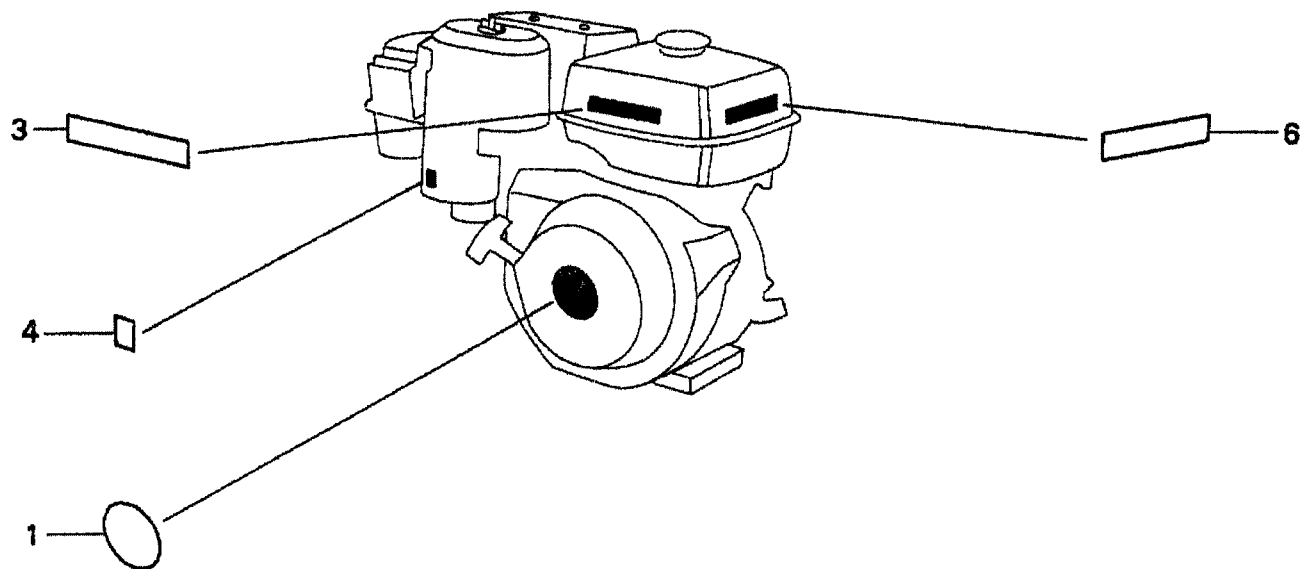
# HONDA GX340K1QAE2 — RECOIL STARTER ASSY.

RECOIL STARTER ASSY.

<u>NO.</u>	<u>PART NO.</u>	<u>PART NAME</u>	<u>QTY.</u>	<u>REMARKS</u>
1	28400ZE3W01ZA	STARTER ASSEMBLY, RECOIL .....	1	INCLUDES ITEMS W/* *R8* BRIGHT RED
2*	28410ZE3W01ZA	CASE, RECOIL STARTER *R8* BRIGHT RED	1	
3*	28421ZE3W01	PULLEY, RECOIL STARTER	1	
4*	28422ZE2W01	RATCHET, STARTER	2	
5*	28441ZE2W01	SPRING, FRICTION	1	
6*	28442ZE2W01	SPRING, STARTER RETURN	1	
7*	28443ZE2W01	SPRING RATCHET	2	
8*	28444ZE2W01	RETAINER, SPRING	1	
9*	28445ZE2W01	HOLDER, SPRING	1	
10*	28461ZE2W02	GRIP, STARTER	1	
11*	28462ZV7003	ROPE, RECOIL STARTER	1	
12*	28469ZE2W01	GRIP, REINFORCEMENT .....	1	USE UP TO ENGINE SN 2935312
13*	90004ZE2W01	SCREW, CENTER	1	
14	957010600800	BOLT, FLANGE 6X8	3	

# HONDA GX340K1QAE2 — LABELS ASSY.

LABELS ASSY.



## HONDA GX340K1QAE2 — LABELS ASSY.

### LABELS ASSY.

<u>NO.</u>	<u>PART NO.</u>	<u>PART NAME</u>	<u>QTY.</u>	<u>REMARKS</u>
1	87521ZE3W01	EMBLEM	1	
3	87522ZH9000	LABEL, CAUTION	1	
4	87528ZE2810	MARK, CHOKE (EXTERNAL)	1	
6	87532ZH8810	MARK, OIL ALERT (E)	1	

**PAYMENT TERMS**

Terms of payment for parts are net 10 days.

**FREIGHT POLICY**

All parts orders will be shipped collect or prepaid with the charges added to the invoice. All shipments are F.O.B. point of origin. Multiquip's responsibility ceases when a signed manifest has been obtained from the carrier, and any claim for shortage or damage must be settled between the consignee and the carrier.

**MINIMUM ORDER**

The minimum charge for orders from Multiquip is \$15.00 net. Customers will be asked for instructions regarding handling of orders not meeting this requirement.

**RETURNED GOODS POLICY**

Return shipments will be accepted and credit will be allowed, subject to the following provisions:

1. A Returned Material Authorization must be approved by Multiquip prior to shipment.
2. To obtain a Return Material Authorization, a list must be provided to Multiquip Parts Sales that defines item numbers, quantities, and descriptions of the items to be returned.
  - a. The parts numbers and descriptions must match the current parts price list.
  - b. The list must be typed or computer generated.
  - c. The list must state the reason(s) for the return.
  - d. The list must reference the sales order(s) or invoice(s) under which the items were originally purchased.
  - e. The list must include the name and phone number of the person requesting the RMA.
3. A copy of the Return Material Authorization must accompany the return shipment.
4. Freight is at the sender's expense. All parts must be returned freight prepaid to Multiquip's designated receiving point.

5. Parts must be in new and resalable condition, in the original Multiquip package (if any), and with Multiquip part numbers clearly marked.
6. The following items are not returnable:
  - a. Obsolete parts. (If an item is in the price book and shows as being replaced by another item, it is obsolete.)
  - b. Any parts with a limited shelf life (such as gaskets, seals, "O" rings, and other rubber parts) that were purchased more than six months prior to the return date.
  - c. Any line item with an extended dealer net price of less than \$5.00.
  - d. Special order items.
  - e. Electrical components.
  - f. Paint, chemicals, and lubricants.
  - g. Decals and paper products.
  - h. Items purchased in kits.
7. The sender will be notified of any material received that is not acceptable.
8. Such material will be held for five working days from notification, pending instructions. If a reply is not received within five days, the material will be returned to the sender at his expense.
9. Credit on returned parts will be issued at dealer net price at time of the original purchase, less a 15% restocking charge.
10. In cases where an item is accepted, for which the original purchase document can not be determined, the price will be based on the list price that was effective twelve months prior to the RMA date.
11. Credit issued will be applied to future purchases only.

**PRICING AND REBATES**

Prices are subject to change without prior notice. Price changes are effective on a specific date and all orders received on or after that date will be billed at the revised price. Rebates for price declines and added charges for price increases will not be made for stock on hand at the time of any price change.

Multiquip reserves the right to quote and sell direct to Government agencies, and to Original Equipment Manufacturer accounts who use our products as integral parts of their own products.

**SPECIAL EXPEDITING SERVICE**

A \$35.00 surcharge will be added to the invoice for special handling including bus shipments, insured parcel post or in cases where Multiquip must personally deliver the parts to the carrier.

**LIMITATIONS OF SELLER'S LIABILITY**

Multiquip shall not be liable hereunder for damages in excess of the purchase price of the item with respect to which damages are claimed, and in no event shall Multiquip be liable for loss of profit or good will or for any other special, consequential or incidental damages.

**LIMITATION OF WARRANTIES**

No warranties, express or implied, are made in connection with the sale of parts or trade accessories nor as to any engine not manufactured by Multiquip. Such warranties made in connection with the sale of new, complete units are made exclusively by a statement of warranty packaged with such units, and Multiquip neither assumes nor authorizes any person to assume for it any other obligation or liability whatever in connection with the sale of its products. Apart from such written statement of warranty, there are no warranties, express, implied or statutory, which extend beyond the description of the products on the face hereof.





# OPERATION AND PARTS MANUAL

## **HERE'S HOW TO GET HELP**

PLEASE HAVE THE MODEL AND SERIAL  
NUMBER *ON-HAND* WHEN CALLING

### ***MULTIQUIP'S MAIN PHONE NUMBERS***

800-421-1244      FAX: 310-537-3927  
310-537-3700

### ***PARTS DEPARTMENT***

800-427-1244      FAX: 800-672-7877  
310-537-3700      FAX: 310-637-3284

### ***MAYCOPARTS***

800-306-2926      FAX: 800-672-7877  
310-537-3700      FAX: 310-637-3284

### ***SERVICE DEPARTMENT***

800-478-1244      FAX: 310-537-4259  
310-537-3700

### ***MQ POWER SERVICE DEPARTMENT***

800-835-2551      FAX: 310-638-8046  
310-537-3700

### ***TECHNICAL ASSISTANCE***

800-478-1244      FAX: 310-631-5032

### ***WARRANTY DEPARTMENT***

800-421-1244, EXT. 279      FAX: 310-537-1173  
310-537-3700, EXT. 279



**MULTIQUIP INC.**  
POST OFFICE BOX 6254  
CARSON, CA 90749  
310-537-3700 • 800-421-1244  
FAX: 310-537-3927  
E-MAIL: mq@multiquip.com  
WWW: multiquip.com

Atlanta • Boise • Dallas • Houston • Newark  
Quebec, Canada • Manchester, UK • Rio De Janeiro, BR • Guadalajara, MX



manufactured for Multiquip Inc.  
by  
**MIKASA SANGYO CO., LTD.** Tokyo, Japan